

Minki Kim

# DIARY

----- in Stitches -----



## 65 Charming Motifs

6 FABRIC & THREAD PROJECTS  
TO BRING YOU JOY

Minki Kim

# DIARY

----- in Stitches -----

## 65 Charming Motifs

6 FABRIC & THREAD PROJECTS  
TO BRING YOU JOY



stashBOOKS®  
an imprint of C&T Publishing

Text and photography copyright © 2018 by Minki Kim

Photography and artwork copyright © 2018 by  
C&T Publishing, Inc.

**Publisher:** Amy Marson

**Creative Director:** Gailen Runge

**Acquisitions Editor:** Roxane Cerda

**Managing Editor:** Liz Aneloski

**Editor:** Karla Menaugh

**Technical Editor:** Debbie Rodgers

**Cover/Book Designer:** April Mostek

**Production Coordinator:** Tim Manibusan

**Production Editor:** Jennifer Warren

**Illustrator:** Valyrie Gillum

**Photo Assistant:** Mai Yong Vang

**Photography** by Minki Kim unless otherwise noted.

Published by Stash Books, an imprint of C&T Publishing, Inc.,  
P.O. Box 1456, Lafayette, CA 94549

All rights reserved. No part of this work covered by the copyright hereon may be used in any form or reproduced by any means—graphic, electronic, or mechanical, including photocopying, recording, taping, or information storage and retrieval systems—without written permission from the publisher. The copyrights on individual artworks are retained by the artists as noted in *Diary in Stitches*. These designs may be used to make items for personal use only and may not be used for the purpose of personal profit. Items created to benefit nonprofit groups, or that will be publicly displayed, must be conspicuously labeled with the following credit: "Designs copyright © 2018 by Minki Kim from the book *Diary in Stitches* from C&T Publishing, Inc." Permission for all other purposes must be requested in writing from C&T Publishing, Inc.

Attention Copy Shops: Please note the following exception—publisher and author give permission to photocopy pages 23, 24, 31, 32, ; even pages 50–76; pages 78–80; even pages 82–92; and pages 95, 96, 99–102, 104–108, and 110–119 for personal use only.

Attention Teachers: C&T Publishing, Inc., encourages you to use this book as a text for teaching. Contact us at 800-284-1114 or [ctpub.com](http://ctpub.com) for lesson plans and information about the C&T Creative Troupe.

We take great care to ensure that the information included in our products is accurate and presented in good faith, but no warranty is provided, nor are results guaranteed. Having no control over the choices of materials or procedures used, neither the author nor C&T Publishing, Inc., shall have any liability to any person or entity with respect to any loss or damage caused directly or indirectly by the information contained in this book. For your convenience, we post an up-to-date listing of corrections on our website ([ctpub.com](http://ctpub.com)). If a correction is not already noted, please contact our customer service department at [ctinfo@ctpub.com](mailto:ctinfo@ctpub.com) or P.O. Box 1456, Lafayette, CA 94549.

Trademark (™) and registered trademark (®) names are used throughout this book. Rather than use the symbols with every occurrence of a trademark or registered trademark name, we are using the names only in the editorial fashion and to the benefit of the owner, with no intention of infringement.

Library of Congress Cataloging-in-Publication Data

Names: Kim, Minki, 1973- author.

Title: *Diary in stitches* : 65 charming motifs – 6 fabric & thread projects to bring you joy / Minki Kim.

Description: Lafayette, CA : C&T Publishing, Inc., [2018] | Includes bibliographical references.

Identifiers: LCCN 2017050078 | ISBN 9781617456510 (soft cover)

Subjects: LCSH: Embroidery, Machine--Patterns. | Machine applique--Patterns.

Classification: LCC TT772 .K56 2018 | DDC 746.44/5--dc23

LC record available at <https://lccn.loc.gov/2017050078>

10 9 8 7 6 5 4 3 2 1



## Dedication

For Mom and Dad in Korea.  
I realize your love each day.

For my husband, Alex, and my three C's—  
Caylin, Chloe, and Claire. You are my  
inspiration and my world.



## Acknowledgments

It all started with a promise to myself: one drawing a day.

I am so grateful to C&T Publishing for believing in me (*again!*) and for beautifully making my half-a-year's worth of drawings into my second book. I would especially like to thank Diane, Karla, Liz, Lucy, and Roxane. You are an awesome team; it was a pleasure to work with you.

Thanks to Kristyne Czepuryk for testing my quilt pattern and contributing her mini quilt to this book. I am fortunate to call you my friend.

Thanks to Elise Baek, who spent her personal time to test patterns and helped me make a better book.

Thanks also to Kristin Esser, who always encouraged me and was the first critic of my designs and drafts. Having a friend who writes and sews makes me the lucky person.

Thank you to the companies that supported me with materials to create these projects: Art Gallery Fabrics, Aurifil, Ava & Neve, Clover USA, Dailylike Canada, Fat Quarter Shop, LECIEN Corporation, Ministry of Fabric, Moda Fabrics, OLFA Craft North America, Quilters Dream Batting, Reliable Corporation, Riley Blake Designs, Tilda Australia, and The Warm Company. Your materials are always best friends for my sewing time. I truly appreciate you for trusting me and supporting me without question.

# Contents

Introduction 6

Basic Techniques and Supplies 7

Projects 17

18 *Strawberry Zipper Pouch*

*Pretty Sewing Machine Cover* 38

25 *Darling Sewing Case*

*Rainbow Ribbons Mini Quilt* 42

33 *Sweet Notes Wall Pocket*

*Find Your Own Path Pillow* 46



## Stitches and Patterns 49

Dear Diary 50

Just Begin 50

I Choose Today 52

Stay True 54

Shine Your Light 56

The Secret of Getting Ahead 58

Spring Has Sprung 60

Life with You Is Always a Picnic 62

Add a Whole Lot of Love  
to Everything You Create 64

No Place like Home 66

Begin Each Day with a Grateful Heart 68

Hooray It's Today 70

Simple as That 72

Little Moments 74

### FIND YOUR VOICE 76

Find Your Own Path 78

Good Things Happen  
When You Go for It 80

Thank You 82

Away 84

A Girl with Bunny 1 86

A Girl with Bunny 2 88

Flower and Wreath Hanging 90

You Are Loved 92

Little Girl with Bear and Bunny 94

Sweet Note 96

Sewing Room 98



## Medium Motifs for a Special Day 100

Scissors and Spool 100

Flower Bouquet 101

### LOVE YA 102

Just Begin Wording 104

We Have Each Other 105

## Small Motifs for Every Day 106

Ribbons 106

### STRAWBERRY BOUQUET 106

Knitting Chick 107

Tulips (Set of Two) 107

My Kitchen (Set of Eight) 108

Rain Boots 110

Flower in a Bottle 110

More from My Kitchen (Set of Five) 111

Hoops for Home 112

### DUCK AND BIRD HOOPS (Set of Three) 112

Mini Hoops (Set of Three) 113

House Hoops (Set of Three) 114

Stitched Christmas 117

### SNOWMAN 117

Christmas Wishes (Set of Four) 118

Doggy with Gift Boxes 119

Christmas Stockings 119



## Gallery of Project Ideas 120

## About the Author 127



# Basic Techniques and Supplies

I hope you have fun stitching these fabric-and-thread illustrations. They are so easy! Just transfer the design to a background fabric using your favorite method, add bits of appliqué fabric to some elements of the design, and stitch around it all on your sewing machine, using a short stitch length and going as slowly as you wish. In no time,

you will have a stitched illustration to sew into a zipper pouch, mini quilt, or another project! You could even hand embroider for an equally charming effect.

If you want even more information about the many ways you can use these techniques, see my first book, *Sew Illustrated—35 Charming Fabric & Thread Designs* (by C&T Publishing).



A variety of tools for sewing. While you could also hand embroider using the hoop, you won't need it for the machine-stitched illustrations. You could use the hoop instead to frame your design (page 112).



# Supplies

## BACKGROUND FABRIC

Let's say you are at an art class, and you want to choose your paper. Do you like thin sketchbook paper, watercolor paper, or canvas? White solid cotton is like thin sketchbook paper. Linen and linen-cotton mixes are like watercolor paper. You can even choose actual canvas material, which many textile artists use as a foundation.

I personally like linen. In my first book, *Sew Illustrated—35 Charming Fabric & Thread Designs*, I used 100% linen on many projects. I have found, however, that a linen-cotton mix is easier to handle than 100% natural linen, and the lighter color of the mix helps the design stand out.

## THREADS

Thread on fabric is similar to a pen on paper, and choosing a thread is like choosing a pen. There's no right or wrong answer. Do you prefer fine-tip or bold-tip pens? Do you tend to use bright colors or basic colors like black, red, and blue? The choice is dependent upon your preference and what will work best for your project.

I used a 50-weight dark-purple cotton thread on most of my sewing illustrations because I was in the mood for a fine-tip pen. You might ask, "Why purple, and not brown or black?" I hardly ever choose black because I try to avoid its bold and cold look. Try any dark-color thread you have around, and you will discover the slightly different feeling that each color creates.

To choose a thread weight, keep in mind that 50-weight threads are like fine-tip pens and 12-weight threads are like bold-tip pens. The 40- and 28-weight threads are in between. Try any weight you feel like, but stitch carefully when you use a 12-weight thread! It is very thick.



### Creating a Mixed-Color Effect

Try a different color of thread in the bobbin. Similar to coloring with a colored pencil, mixing two different thread colors creates a gradient effect. I often use a dark thread in the upper spool and a light thread in the bobbin. This is especially useful when I can't find the right color thread or when I want to tone down a dark color. It helps to stitch some samples, comparing the stitches using the same-color bobbin versus stitches using a different-color bobbin. You will see the difference.

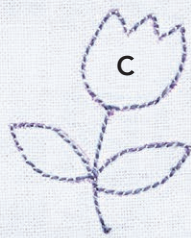
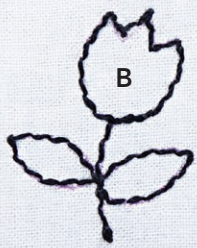

Different thread weights and bobbin colors can create different results.

- A. 50-weight thread
- B. 12-weight thread
- C. 28-weight thread, gray on top and white in bobbin
- D. 28-weight thread, gray on top and black in bobbin

## APPLIQUÉ FABRIC

You've chosen your pen—now let's choose a color palette. Do you like bright colors? Neutral pastel colors? Again, there's no right answer. But if I were you, I would go for a bright color palette because it emphasizes your design on a neutral linen or white solid background. I would also recommend that you try not to overlap similar colors. Lastly, avoid choosing large prints for the background or for the accent fabrics; they distract from your design.

For something different, try using dark background fabrics with brightly colored

thread. This technique creates the charming effect of having drawn on a chalkboard.



We Have Each Other stitchery (page 105): See the project idea (page 123).

## OTHER SUPPLIES

---

These are my favorite notions for making stitched illustrations:

**FriXion pen or air-erasable pen** for transferring designs

**Fusible web** for raw-edge appliqué (I like Lite Steam-A-Seam 2, but use your favorite.)

**Stabilizer** (You can use embroidery backing paper, fusible interfacing, or wash-away stitch stabilizer.)

**Open-toe appliqué foot** to help see where you are stitching

**Ginger 5" embroidery scissors** for cutting the appliqué fabrics

**3½" embroidery scissors** for cutting thread

**Embroidery floss** for filling in empty spaces and decorative stitches

**Machine needles** (Use size 80 for most sewing and size 90 for 12-weight thread.)

For sewing the projects together, I use the following:

**Rotary cutting mat, rotary cutter, and rulers** (I prefer OLFA products.)

**¼" piecing foot**

**Walking foot** for machine quilting

## Techniques

### HOW TO TRANSFER PATTERNS

---

When the background fabric is a thin solid, it's easy to trace the pattern directly onto the fabric by placing the pattern under the fabric. I often use my cell phone as a lightbox when I transfer small designs: I put the fabric and drawing right over the phone screen.

For bigger designs, I tape the pattern and background fabric to a bright window. You can also try a computer monitor. Set the brightness to the highest setting with a blank white page open, and tape the pattern and fabric to the monitor using washi tape. Be careful not to damage your monitor screen.

### Be Brave

When you trace the patterns, do not stress out about tracing the lines exactly. Think of it as drawing your own design. There will be no need to worry about tracing every line perfectly because the design is yours. As long as it's not a human face, a slight difference won't matter and can even add character. Think of how a child can draw two dots on a bunny's face and it's cuter than adult-drawn bunnies. Remember, it's a fun art class and *you* are the artist!

# How to Sew the Illustrations

I am often amazed by quilts with perfectly matched corners and by pot holders with perfectly round and even corners. Sewing these illustrations is *not* harder than sewing those straight lines. The stitch lengths are a bit smaller (usually 1.6 for stitching illustrations compared to 2.5 for general sewing) and it's a mix of straight and curved stitching. If you think of it that way, drawing with thread is not scary at all. You already have more than enough experience, and all you need to do is sew slowly enough to control each stitch. Then you can write a whole essay using your sewing machine, and I bet it would be prettier than my handwriting!

## APPLIQUÉ AND STITCHING

I recommend using fusible web as a backing for the appliqué elements. Since the fusible web will be placed on the back of the fabric, you will need to cut out the pieces with the pattern reversed. You can download and print any of the reversed patterns at [tinyurl.com/11299-patterns-download](http://tinyurl.com/11299-patterns-download). Make sure you print the images at 100% size.

Alternatively, you can make a quick-and-easy reversed template without downloading the pattern. Simply trace or photocopy the pattern onto a sheet of paper, marking the front of each pattern piece. Cut out the pieces to be appliquéd, and turn each appliqué piece over so that the *back* of the piece is faceup.

**1.** Lay the fusible web, paper side up, over the *reversed* pattern. Use a pencil to trace each appliqué piece. You don't need to trace

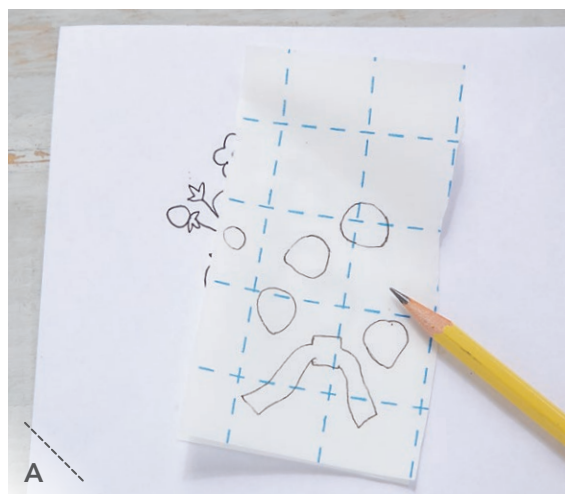

the entire stitched design—just the appliqué pieces. *Optional:* Transfer the appliqué elements to the right side of the fabric(s) you want to use for the appliqués. *Fig. A*

**2.** Cut out each fusible-web shape roughly  $\frac{1}{4}$ " outside the traced line. Stick or lightly fuse onto the *wrong side* of the fabric. Cut out the fabric shape slightly bigger than the traced line. Set the pieces aside. *When you trace any small design, cut out the fabric accent a bit bigger than the traced line. Fig. B*

• **TIP** • I sometimes use an alternate method that saves a little time.

1. Trace the appliqué pattern (not reversed) directly onto the right side of the fabric you want to use for the appliqué element.

2. Peel off the paper from a piece of fusible web approximately the same size, and stick the web on the wrong side of the fabric.

3. Cut out the design, using the traced line on the front of the fabric as a guide. Remember to cut out the fabric a bit larger if it is a really small element.

3. Using a pencil or a temporary marking pen, center and trace the appliqué pattern (not reversed) onto the front of the background fabric. *Fig. C*

4. Arrange the cut-out fabric accents from Step 2 on the marked foundation. Fuse in place following the fusible web manufacturer's instructions. *Fig. D*

#### NOTES

- If my background fabric is thin enough that I can see the pattern through it, I sometimes save time at this stage by placing the pattern behind the fabric. I use it as a guide as I place and fuse the appliqué elements to the background.
- If you wish, you can trace the entire design onto the background fabric in Step 3. Keep in mind, however, that the FriXion pen is heat-erasable. If you use it at Step 3, do not trace the entire design; it will disappear when you fuse in Step 4.



5. Trace the remaining designs on the foundation using a temporary marking pen. Fig. E

6. Add your chosen stabilizer to your background fabric. See How Do I Choose a Stabilizer? (page 15).

7. Set up your sewing machine with dark thread and a stitch length between 1.6 and 1.8 that works for your stitched illustration. The smaller the stitch length, the smoother the stitching lines will appear. Choose a shorter stitch length for designs with a lot of detail and curves. Use a slightly longer stitch length for larger, simpler designs or when you are using really thick thread. I set my stitch length at 3.0 for most 12-weight thread. In each project, I recommend a stitch length for the featured pattern and thread. If your machine doesn't have numbers on the stitch-length gauge, choose a small stitch length.

Put your chosen stabilizer in position. If you have an open-toe appliqué foot, use it so that you will be able to see your stitching more easily. Using a straight stitch, slowly sew just inside the edges of the appliqué pieces and along the rest of the marked lines, reducing the stitch length or backstitching at the beginning and end of each stitched portion. Fig. F

• **TIP** • The 12-weight thread is too thick for nice backstitching at the beginning and end of the lines. Instead, it's best to leave a long thread at the beginning and the end of the stitching. You can tie your loose threads on the back of your work after you finish your stitches.



8. Trim all loose threads. If you used embroidery backing paper as a stabilizer, trim the excess away after the design is complete.

## Frequently Asked Questions

---

### Could I hand embroider these designs?

Any of the designs in this book can be created with hand embroidery if you prefer—the results are equally charming. And you wouldn't have to stop at outlining the appliqué; you could replace the appliqué with traditional hand-embroidered filler stitches. Let your imagination tell you where to go, and use the patterns to make your own style.

### Where should I start stitching?

Find the longest line in the design and start where two lines meet.



### When should I backstitch or lock the stitches?

When you stitch words, lock the stitch at every beginning and end by shortening the stitch length even more instead of backstitching. I think shortening the stitch length is prettier visually.

When stitching a circle or continued line, just overlap it with a few stitches.

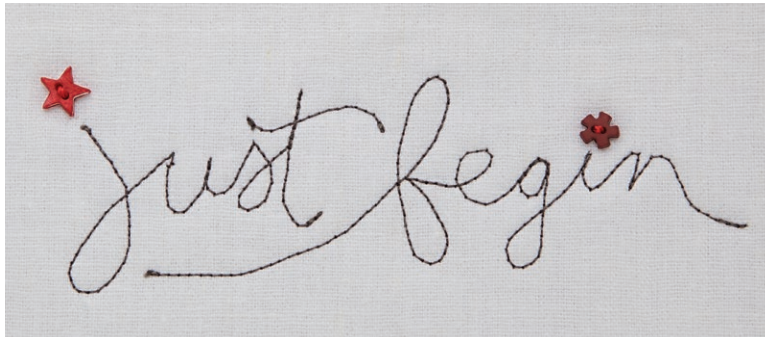

### When should I cut the accent fabric bigger than the pattern?

If the design is small, cut the fabric just a little bit bigger to help prevent fraying.

If the design is big, cut on the design line.

### When do you trim your threads?

I trim periodically. It is easier to work without stray threads getting in the way.



### Do you quilt the background before adding the stitched illustrations, or do you quilt over the illustrations, too?

Most of the time I sew the illustrations first and then quilt over them. The smaller the background fabrics are, the easier it is to sew the stitched illustrations—so it is easier to stitch the illustration first, sew the rest of the project background together, and then quilt it. If the finished project will be small, I use batting as the embroidery backing so that I am quilting as I stitch the design.

### How should I fill in the spaces in the pattern?

Use the backstitch button wisely. It's easier than turning the fabric frequently to fill in the small space.



### How do I choose a stabilizer?

It is easier to choose a stabilizer if you know what you are going to make with the stitchery before you start.

If you think the project will need batting for insulation, like the tea mats in the gallery of project ideas (page 125), use cotton batting as a stabilizer.

If you are going to make hoop art or frame your stitchery in a conventional frame, use fusible interfacing as a stabilizer. Place a hoop-size (or frame-size) piece of fusible batting under the background fabric, and sew the design. After you have finished the stitching, fuse the batting to a backing; it will give you a nice weight for your framed art.

For small quilted projects, like the Darling Sewing Case (page 25), I also placed fusible batting under the entire case body to add some structure to the final product. For most other projects, though, I use embroidery backing or stabilizer behind my background fabric as I stitch the illustration.

You could also use Wash-Away Stitch Stabilizer (by C&T Publishing) on top of your background fabric while you sew. Follow the manufacturer's instructions to copy or print a design onto the stabilizer. Stick the printed stabilizer on top of the fabric, add the appliqué elements, and sew right on top of the stabilizer. When the design is complete, rinse the fabric with cool water to remove the stabilizer and set it aside to dry. If you use the wash-away stabilizer, do not use fusible backing on your appliqué elements. Instead, use a glue stick to hold the fabric accents in place.



Partially stitched Christmas coaster (page 124) with batting used as a stabilizer



## Finishing Your Stitchery

### WHAT ELSE CAN I DO WITH THIS METHOD?

For my daughter's birthday I made six goody bags, each stitched with a child's name. It took less than an hour. If hand embroidery had been the only way to stitch the names, I would not have even started. You can quickly sew your own initials or your child's drawing without spending a whole day. And you can make a one-of-a-kind card by sewing some stitches onto the paper. See the gallery of project ideas (page 120) for some ideas on how you can use your stitchery.

### QUILTING AND BINDING

Use your favorite method to quilt and bind your projects. If you are new to these techniques, check your local quilt shop for classes or look online for instructional videos. For more quilting and binding information, refer to [ctpub.com](http://ctpub.com) > scroll down to Support: Quiltmaking Basics & Sewing Tips > scroll down to Downloads > How to Finish Your Quilt.



The ribbon motif in *Rainbow Ribbons Mini Quilt* (page 42) is perfect for small pincushions to gift your friends. See more ideas in the gallery of project ideas (page 120).

# PROJECTS



# Strawberry Zipper Pouch

Finished pouch: 6½" wide × 6½" high × 3" deep



## Materials and Supplies

See *Supplies* (page 8) for additional information and a full list of notions.

**Assorted print scraps** for appliqué pieces

**Linen-cotton mix:** 1 piece 10½" × 10½" for stitched illustration background and pouch closure

**Print 1:** 1 piece 8½" × 20" for pouch exterior

**Print 2:** 1 piece 10½" × 17" for lining

**Medium-weight fusible batting:** 1 piece 10" × 16"

**Fusible web**, like Lite Steam-A-Seam 2

**Zipper:** 8"

**½"-wide cotton ribbon:** 2" length for tab (*optional*)

**Thread:** Dark purple (50-weight preferred) for stitched illustration, green thread or embroidery floss for leaves, neutral (ivory) for pouch construction, and ivory heavy quilting thread for sewing in zipper

## Cutting

For the lining, see the *Strawberry Zipper Pouch* pattern (pages 23 and 24).

**Linen-cotton mix:** Cut 1 rectangle 3½" × 8½" and 2 bias strips 1½" × 8".

**Print 1:** Cut 1 (large) rectangle 8½" × 10½" and 2 (small) rectangles 4" × 8½".

**Print 2:** Cut 1 from the pattern using the outer line.

**Medium-weight fusible batting:** Cut 1 from the pattern using the inner line.

Just when I started learning how to use a sewing machine, I received a zipper pouch as my very first gift from a blog friend. It was like having an answer sheet for math problems, as I was a complete beginner. By looking at the pouch, I could learn how she made the pouch body stable and how she attached and finished the zipper.

Not only a valuable DIY lesson, the pouch was also so practical that I could take it inside my bag anywhere I went. Ever since, a zipper pouch has been my favorite project—especially when it is time to make a gift for someone. For this pouch, I chose a cheater cloth print that looks like pieced hexagons for the exterior (Hexagon cheater print from 30's Collection by Atsuko Matsuyama for Yuwa Fabrics). To trick the eye a little bit more, I quilted along the hexagons. I hope my Strawberry Zipper Pouch becomes your new on-the-go friend!

# Instructions

Seam allowances are  $\frac{1}{4}$ " unless otherwise noted.

## APPLIQUÉ AND STITCH THE DESIGN

1. Refer to Techniques (page 10) to stitch the design onto the  $3\frac{1}{2}$ "  $\times$   $8\frac{1}{2}$ " linen-like rectangle, centered horizontally and 2" below the top edge. You can use the Strawberry Bouquet pattern (page 106) or another pattern of your choice. I used a 1.6 stitch length for this design. *Fig. A*

2. After you have completed the illustration, change the thread color to green on both the upper spool holder and the bobbin. Fill in the leaves using the backstitch button, or hand stitch using green embroidery thread. *Figs. B & C*

• **TIP** • When you fill in small spaces, stitching straight forward and then backstitching is easier than cutting out little fabric pieces and fusing. If hand embroidery is more comfortable for you, hand stitch the small spaces instead.

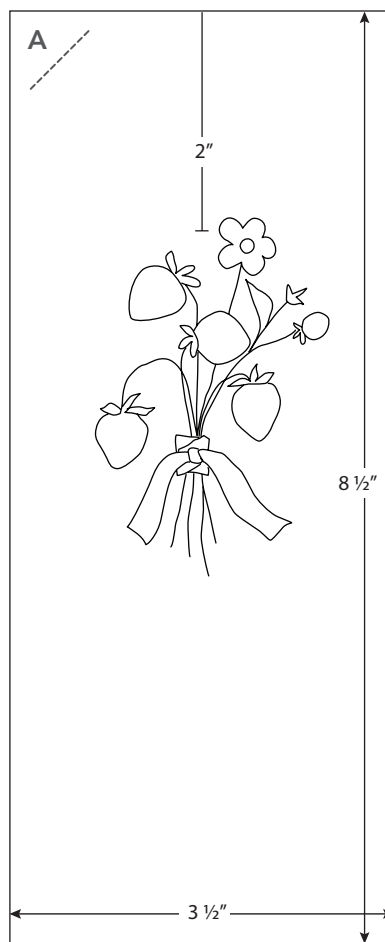

## MAKE THE POUCH BODY

**1.** Sew a small print 1 rectangle to each long side of the stitched illustration. Press the seam allowances toward the linen. Sew the large print 1 rectangle to the bottom edge of the linen unit, and press the seam allowance toward the linen. *Fig. D*

**2.** On the wrong side of the pieced unit from Step 1, mark the center of each side. Using a template made from the Strawberry Zipper Pouch pattern (pages 23 and 24), cut out the fusible batting and mark the center of the bottom and top. Matching the centers, press the fusible batting to the wrong side of the pouch. *Fig. E*

**3.** Quilt along the lines in the print fabric or as desired.

**4.** Draw a cutting line  $\frac{1}{4}$ " outside the batting along the sides but not on the curved pouch top. Cut away the excess fabric. *Fig. F*

**5.** Fold the pouch body in half, right sides together, and align the curved edges. Clip each top corner, as shown. Sew the short ends, backstitching at the beginning and end. Press the seam open.

*Optional:* Add the tab. Before stitching the right-hand side, fold the ribbon in half and slip the folded edge in between the pouch sides, 1" from the top and matching the raw edges. *Fig. G*

**6.** Flatten out the bottom of the pouch to match the corners. Pin and stitch across the raw edges, backstitching to secure the pouch corners. *Fig. H*

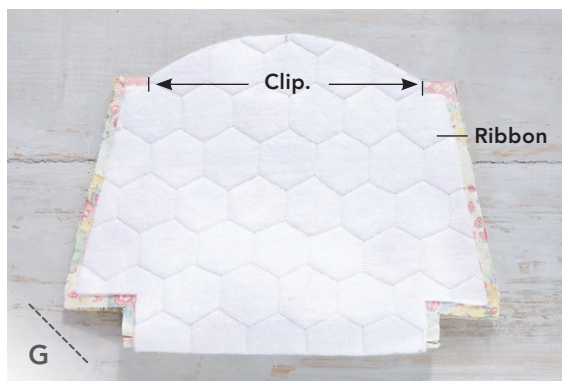

## MAKE THE LINING

Using the lining piece, follow Make the Pouch Body, Steps 5 and 6 (page 21) to make the pouch lining. Clip the upper edge, as shown. *Fig. I*

## ASSEMBLE THE POUCH

1. Turn the pouch right side out and slip the lining inside, wrong sides together. Match both clipped seam sides. Fold the seam allowance in and hand stitch together. *Fig. J*

2. Fold in  $\frac{1}{4}$ " on each short end of a linen bias binding strip. Press the binding in half lengthwise. Pin the binding to a top front edge of the pouch, matching the raw edges of the binding, exterior, and lining. The bias strip might be a little longer than needed after pinning. If so, cut it to size and refold the trimmed end. Machine stitch the binding to the pouch. Turn the folded edge of the binding to the inside of the pouch, and blind-stitch it in place by hand.

3. Repeat Step 2 to bind the other side of the pouch. *Figs. K–M*

4. With the pouch body inside out, align the stitching line of the zipper with the stitched edge of the bias strips; pin in place. Stitch in place by hand using a running stitch and a strong thread such as polyester or heavy quilting thread. Fold under the zipper ends, as shown, and stitch to secure. *Fig. N*

• **TIP** • Another way to install the zipper is to fold in the edge of zipper and blindstitch all the way around to secure. Fold both short ends under and hide with slip stitches.

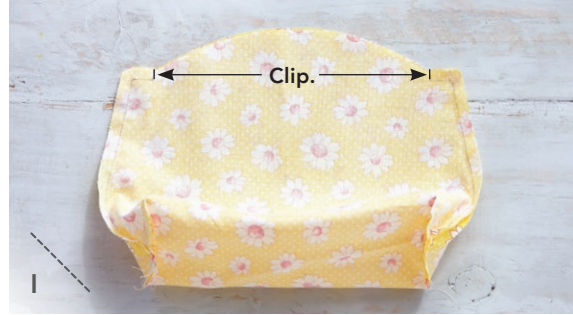

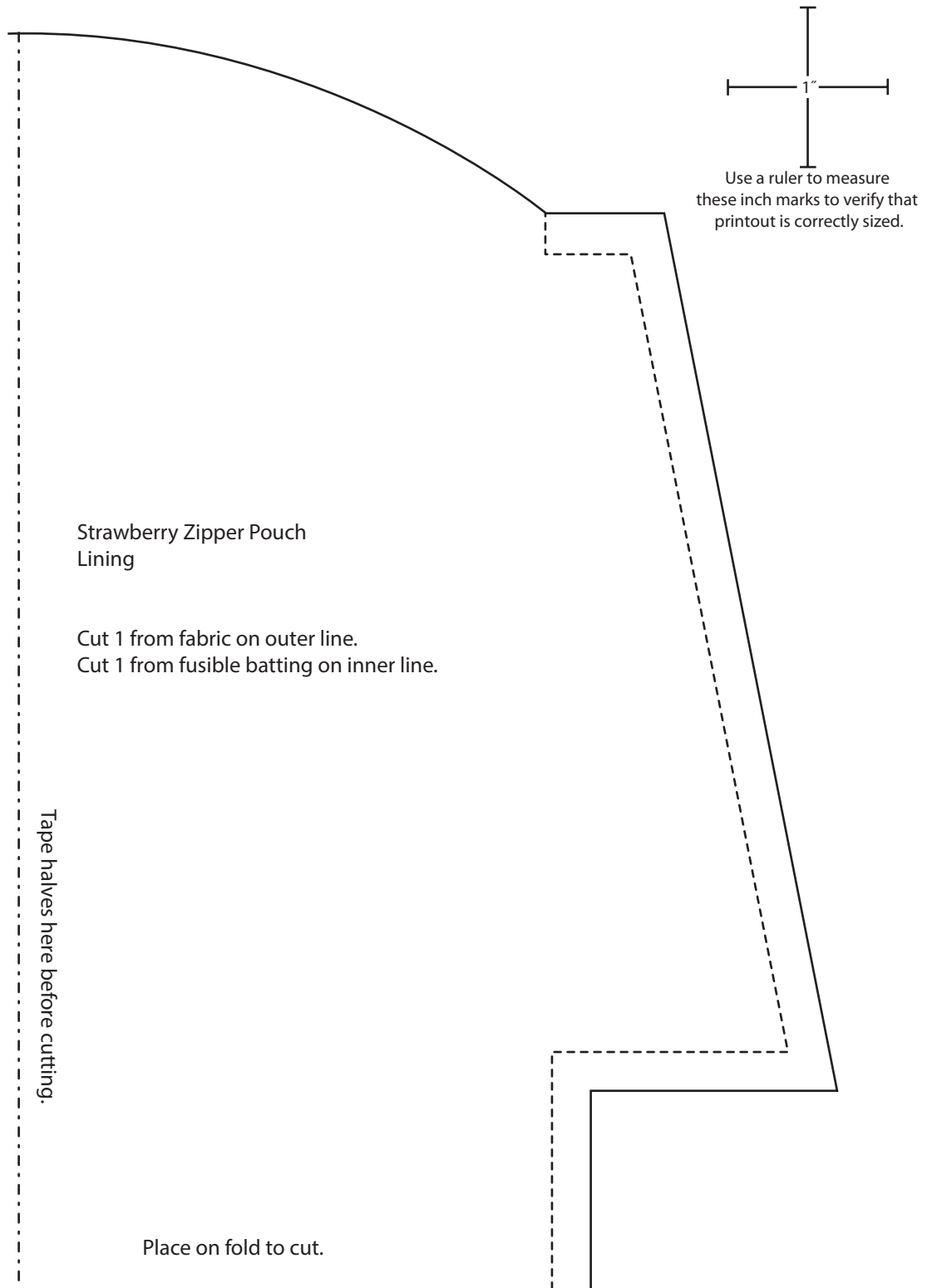



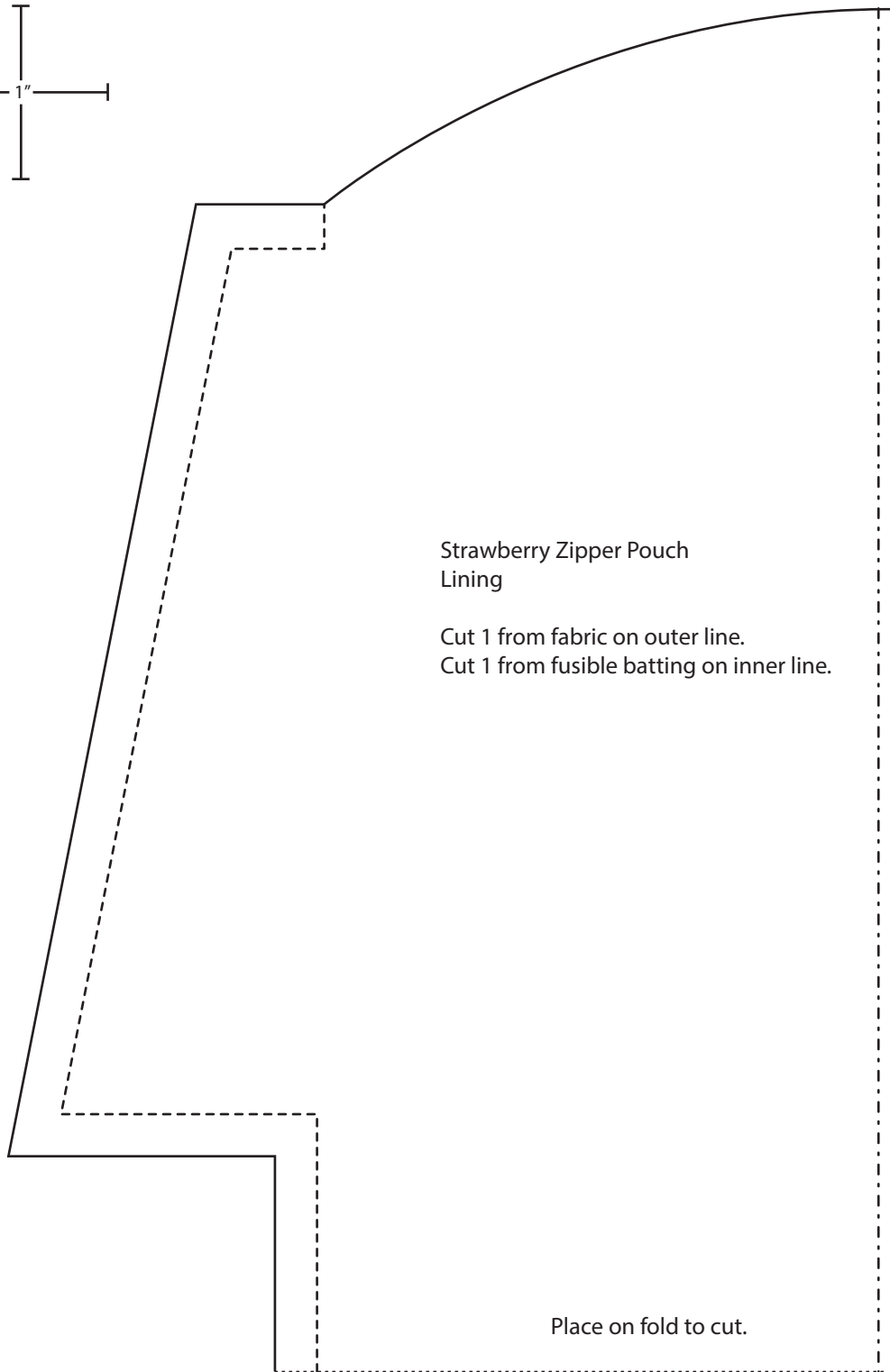
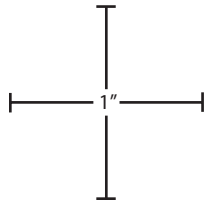

Strawberry Zipper Pouch  
Lining

Cut 1 from fabric on outer line.  
Cut 1 from fusible batting on inner line.

Tape halves here before cutting.

Place on fold to cut.

# Darling Sewing Case

Finished case: 8" wide × 4" high × 4" deep



The charm of sewing is that I can make anything I want—anything I can dream of with only fabric and a sewing machine. I believe that my current project is always the best, and I can do better next time. So for me, sewing always has a happy result.

Make your best sewing case today and promise yourself that you will do better tomorrow. If you would like a different-size case, just enlarge or reduce the Darling Sewing Case pattern (pages 31 and 32) and the case top and case body pieces accordingly to make a case for any purpose!

## Materials and Supplies

See *Supplies* (page 8) for additional information and a full list of notions.

**Assorted print scraps** for appliqué pieces

**Print 1:** 1 piece at least 5" × 9" for case top

**Print 2:** 1 piece at least 13" × 13" for case body

**Print 3:** 1 piece 13" × 17" for case lining

**Fabric scrap:** 1 piece 1¾" × 3½" for closure tab

**Medium-weight fusible batting:** 1 piece 13" × 17"

**Fusible interfacing:** 1 piece 13" × 17"

**Fusible web**, like Lite Steam-A-Seam 2

**Cotton batting:** 1¾" × 3"

**½"-diameter circle magnets:** 2 (You can find these at craft stores.)

**Thread:** Dark gray (28-weight preferred) for stitched illustration, ivory for case construction, and pink embroidery floss to outline top edges and optional bottom board

**Hardboard:** 4" × 8" for case bottom (*optional*; available at craft stores)

## Cutting

For the lining, see the *Darling Sewing Case* pattern (pages 31 and 32).

**Print 1:** Cut 1 rectangle 5" × 9".

**Print 2:** Cut 1 square 13" × 13".

**Print 3:** Cut 1 from the pattern using the outer line.

**Medium-weight fusible batting:** Cut 1 from the pattern using the inner line.

**Fusible interfacing**

- Cut 1 from the pattern using the inner line.
- Cut 1 square 1" × 1".

# Instructions

Seam allowances are  $\frac{1}{4}$ " unless otherwise noted.

## APPLIQUÉ AND STITCH THE DESIGN

1. Refer to Techniques (page 10) to stitch the design onto the 5" × 9" rectangle for the case top. You can use the Scissors and Spool pattern (page 100) or another pattern of your choice. I used a 1.8 stitch length for this design.

• **TIP** • Clip a  $\frac{1}{4}$ " slit in the center of the scissor handles to cut out the inside circles.

2. Trim the case top to  $4\frac{1}{2}$ " ×  $8\frac{1}{2}$ ". *Fig. A*

## MAKE THE CASE BODY

1. Center the appliquéd print rectangle on one side of the print 2 square, right sides together. Stitch and press the seam allowance toward the case top. *Fig. B*

2. Place the fusible batting lining piece on the back of the top/body unit, as shown. Fuse in place. *Fig. C*

3. Leaving a  $\frac{1}{4}$ " seam allowance all the way around, trim the excess fabric. Quilt as desired. I quilted diagonal lines 1" apart using matching colored thread. Do not quilt the appliquéd top. *Fig. D*

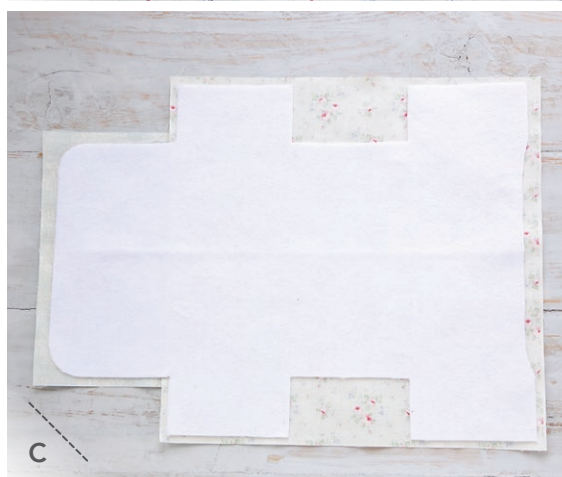

## MAKE THE CLOSURE

1. Center the  $1\frac{3}{4}$ "  $\times$  3" cotton batting on top of the  $1\frac{3}{4}$ "  $\times$   $3\frac{1}{2}$ " closure tab. *Fig. E*
2. Fold in half, right sides together, and sew both sides. *Fig. F*
3. Turn right side out and slip in a  $\frac{1}{2}$ " circle magnet. *Fig. G*
4. Pin and stitch the magnet closure to the center of the flap. *Fig. H*



## FINISH THE CASE BODY

1. Fold and pin the case body in half, aligning both sides. Sew both sides. *Fig. I*
2. Bring the raw edges of a notch together and flatten it out so the fold meets the case's side seam. Pin and stitch across the raw edges. Lock each start and end by backstitching a couple times to secure. *Figs. J & K*

## MAKE THE LINING

1. Center the fusible interfacing on the wrong side of the lining fabric; fuse in place. *Fig. L*
2. Repeat Finish the Case Body (above) to make the case lining, except leave a 3" opening in one side for turning. *Fig. M*



## ASSEMBLE THE CASE

1. Mark the center on the case front. Use the 1" square of fusible interfacing to attach the ½" circle magnet with hand stitching. *Fig. N*

• **TIP** • Check the magnet side of the tab before attaching to be sure the magnets connect.

2. Make a ¼" clip into the corners of the side seam allowances. *Fig. O*

3. Place the lining inside the case body, right sides together. Pin in place and stitch all the way around. *Fig. P*

4. Turn the case right side out.

5. *Optional:* Insert a 4" × 8" hardboard through the lining opening for the case bottom. Topstitch around the bottom board by hand using 3 strands of pink embroidery floss. *Fig. Q*

6. Close the opening in the lining with hand stitching. Topstitch around the edge of the top and upper edge of the case by hand, using 3 strands of pink embroidery floss. *Fig. R*

• **TIP** • Fold hand towels in the shape of the case. Place them inside and press the case into shape. Let it stand until cooled or overnight to hold good shape.



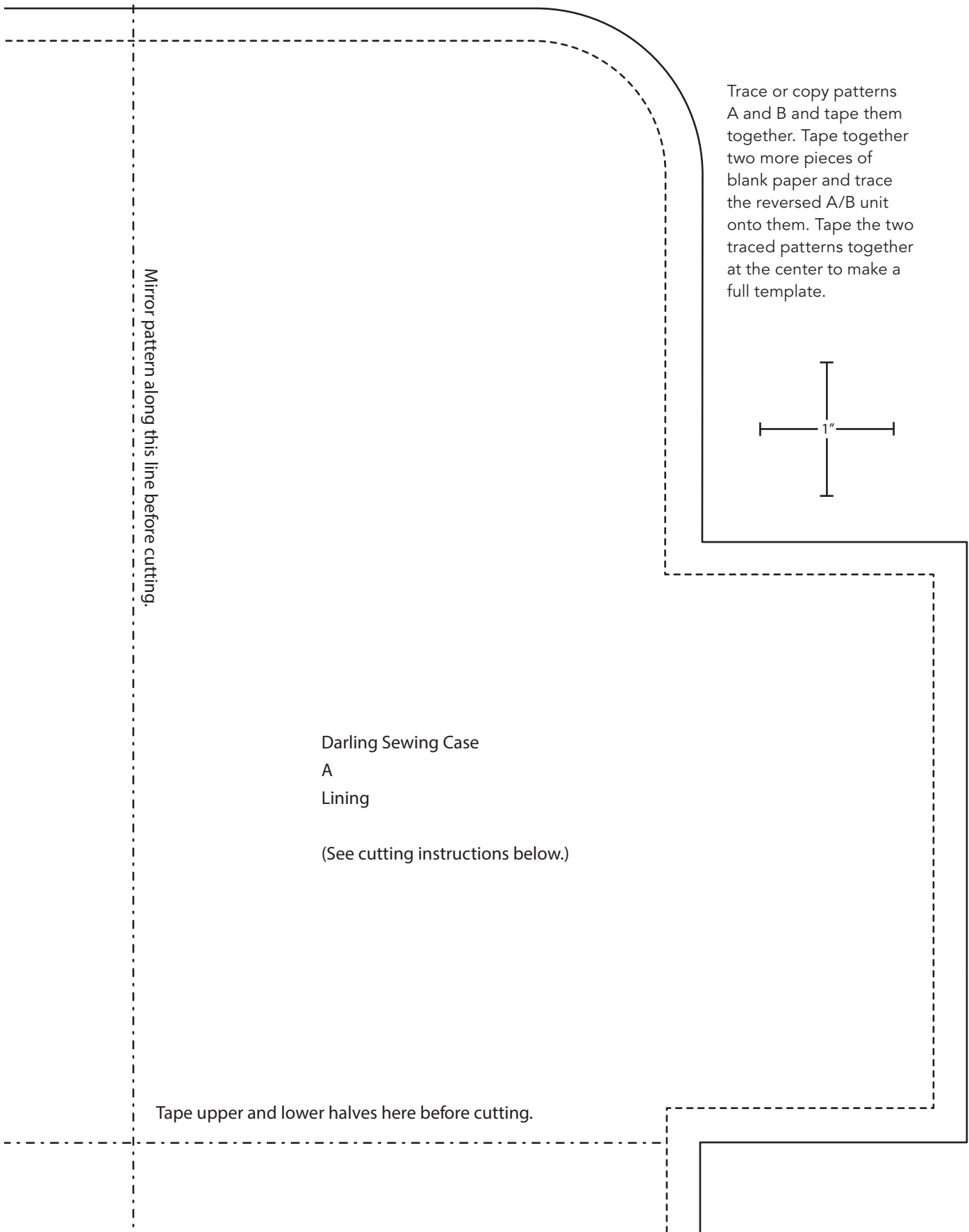

Trace or copy patterns A and B and tape them together. Tape together two more pieces of blank paper and trace the reversed A/B unit onto them. Tape the two traced patterns together at the center to make a full template.

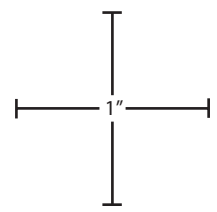

Darling Sewing Case  
A  
Lining

(See cutting instructions below.)



Tape upper and lower halves here before cutting.

Mirror pattern along this line before cutting.

Darling Sewing Case

B

Lining

Cut 1 from fabric on outer line.

Cut 1 from fusible batting on inner line.

Cut 1 from fusible interfacing on inner line.

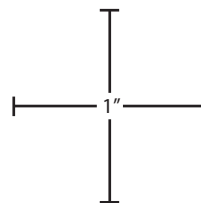

# Sweet Notes Wall Pocket

Finished wall pocket: 13" x 16½"



I have several boxes that are filled with handmade cards from crafty friends, letters from my family in Korea, postcards, and even drawings from my girls when they were kindergartners. A big fat box is a very safe place to store old memories—but also easily forgettable. So I have started to make wall pockets and hang them where I can look at my sweet notes often. Thoughtful notes often remind me of how grateful I am for the senders and how their kind words are powerful.

The embroidery-style print at the bottom of the wall pocket is from my fabric collection Dear Diary for Riley Blake Designs. Make your Sweet Notes Wall Pocket and store your sweet notes!

## Materials and Supplies

See *Supplies* (page 8) for additional information and a full list of notions.

### Assorted floral prints

for appliqué pieces

### Linen:

1 piece 9" × 10"  
for stitched illustration background

### Print 1:

1 piece at least 7½" × 8"  
for wall pocket center

### Print 2:

1 piece 7½" × 14"  
for borders

### Print 3:

1 piece at least 8" × 9"  
for linen pocket lining

### Print 4:

1 piece at least 6½" × 13"  
for bottom pocket

### Print 5:

1 piece at least 6" × 13"  
for bottom pocket

### Print 6:

1 piece 6½" × 15½"  
for bottom pocket lining and  
top corner triangle accent

### Backing:

½ yard

### Binding:

⅛ yard

### Cotton batting:

14" × 17½"

### Fusible interfacing:

¼ yard  
to reinforce bottom pocket

### Fusible web,

like Lite Steam-A-Seam 2

**Thread:** Dark purple (50-weight preferred) for stitched illustration, neutral (ivory) for wall-pocket construction, and ivory embroidery floss for hand quilting

¼"-diameter (0.7 cm-diameter)  
eyelets: 2

kraft-tex, leather, or felt scraps  
(optional)

## Cutting

**Print 1:** Cut 1 rectangle 7½" × 8"  
for the center.

### Print 2

- Cut 2 rectangles 3½" × 8" for the side borders.
- Cut 1 rectangle 3¾" × 13½" for the top border.

**Print 3:** Cut 1 rectangle 8" × 9" for the linen pocket lining.

**Print 4:** Cut 1 rectangle 6½" × 13" for the bottom.

**Print 5:** Cut 1 rectangle 5¾" × 13" for the bottom pocket.

### Print 6

- Cut 1 rectangle 6¼" × 13" for the bottom pocket lining.
- Cut 1 square 2½" × 2½" for the top corner triangle accent.

**Backing:** Cut 1 rectangle 15" × 18½".

**Binding:** Cut 2 strips 2¼" × 42".

### Fusible interfacing:

Cut 1 rectangle 5¾" × 13" for the bottom pocket.

# Instructions

Seam allowances are  $\frac{1}{4}$ " unless otherwise noted.

## APPLIQUÉ AND STITCH THE DESIGN

1. Refer to Techniques (page 10) to stitch the design onto the 9" x 10" linen rectangle. You can use the Sweet Note pattern (page 96) or another pattern of your choice. I used a 1.6 stitch length for this design.

2. Trim the stitched linen to 8" x 9". Fig. A

## ASSEMBLE THE POCKET UNIT

1. Sew the  $3\frac{1}{2}$ " x 8" side border pieces to the right and left of the  $7\frac{1}{2}$ " x 8" print 1 piece. Sew the  $3\frac{3}{4}$ " x  $13\frac{1}{2}$ " top border piece on top. Fig. B

2. Sew the 8" x 9" print 3 piece and the linen appliqué pieces together along the top edge. Fold with the wrong sides together and press. Fig. C

3. Place the linen pocket on the main unit at an angle, as shown, with the stitched illustration at least  $\frac{1}{2}$ " above the lower edge. Use a ruler and fabric marker to draw the cutting lines, extending the sides of the pocket up onto the background. Fig. D

4. Pin the linen pocket in place. Trim the background on the lines. Fig. E



5. Sew both cut-off pieces to the linen unit again, aligning each at the top. *Fig. F*
  6. Trim the bottom edge to be parallel to the top, leaving at least  $\frac{1}{2}$ " below the bottom edge of the stitched illustration. Sew the  $6\frac{1}{2}$ "  $\times$  13" print 4 rectangle to the bottom of the pocket unit.
  7. Make a quilt sandwich by placing the backing fabric right side down, the batting on top, and then the pocket unit centered and right side up. Baste the layers together using your preferred method. (I sprayed a basting spray between the layers.) *Fig. G*
  8. Attach a walking foot to your sewing machine and quilt as desired, making sure not to stitch over the linen pocket. Trim to a 13"  $\times$  16 $\frac{1}{2}$ " rectangle.
  9. Place the  $2\frac{1}{2}$ "  $\times$  2 $\frac{1}{2}$ " print 6 square on the top right edge and sew diagonally from corner to corner, as shown. Fold the edge toward the right corner to create a triangle. *Fig. H*
  10. Press the fusible interfacing on the wrong side of the  $5\frac{3}{4}$ "  $\times$  13" print 5 rectangle. Sew this rectangle to the  $6\frac{1}{4}$ "  $\times$  13" print 6 pocket lining along the top edge. Press the seam allowance toward the lining. Fold the joined rectangles in half, wrong sides together, and align the lower edges to make a pocket. The lining print will extend  $\frac{1}{4}$ " above the pocket front. *Fig. I*
  11. Layer the pocket atop the quilted unit, aligning the bottom edges. Pin in place.
- Optional:* Stitch the side and bottom edges together with a zigzag stitch. *Fig. J*



## FINISH THE WALL POCKET

1. Bind the edges of the wall pocket using your favorite binding technique (page 16).
2. Attach an eyelet to both top corners of the wall pocket, following the manufacturer's instructions.

*Optional:* Before attaching the eyelets, cut 2 circles  $\frac{1}{2}$ " in diameter from kraft-tex (by C&T Publishing) or a leather scrap. Punch a hole in the center of each circle, and attach one under each eyelet to help strengthen the area around it. *Fig. K*

• **TIP** • After the wall pocket is bound, add some hand stitching between the machine-quilted sewing lines to add some character to the quilting.

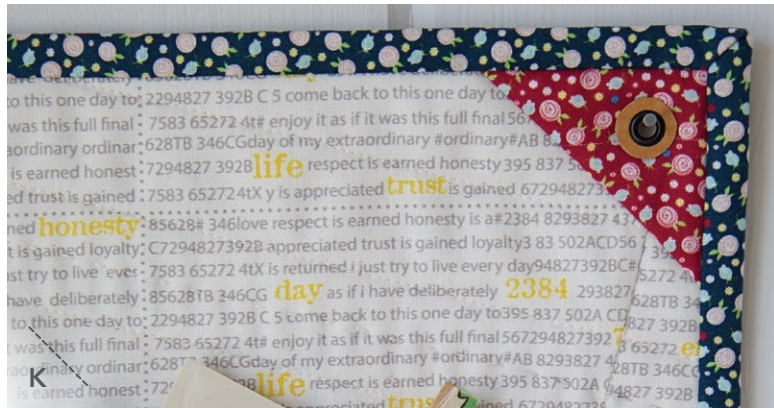

# Pretty Sewing Machine Cover

Finished cover: 14" x 27½"



## Materials and Supplies

See *Supplies* (page 8) for additional information and a full list of notions.

**Assorted print scraps:** 84 scraps at least 1½" × 1½" for appliqué pieces and patchwork squares

**Linen:** 1 fat quarter for cover exterior

**Print 1:** ½ yard for lining

**Print 2:** ⅛ yard for accent strips

**White solid:** 1 square 3" × 3" for appliqué patch on back

**Fusible interfacing:** ½ yard to reinforce cover

**Fusible web,** like Lite Steam-A-Seam 2

**Thread:** Dark gray (28-weight preferred) for stitched illustration, neutral (ivory) for construction, and white (12-weight preferred) for topstitching

## Cutting

**Assorted print scraps:** Cut 84 squares 1½" × 1½" for the patchwork.

**Linen:** Cut 1 rectangle 14½" × 21".

**Print 1:** Cut 1 rectangle 14½" × 28".

**Print 2:** Cut 2 strips 1" × 14½".

**Fusible interfacing**

- Cut 1 rectangle 14½" × 29".

- Cut 1 square 3" × 3".

- **TIP** • Measure your sewing machine and adjust the size of the cover, if necessary.

One day, I folded up all my fabric scraps nicely and placed them in a big, wide drawer. Whenever I opened the drawer and peeked at those colorful prints, I thought I had done a very good job of organizing them. It didn't take long to realize, though, that hiding fabrics was not helpful for project inspiration. Since then, I have tried to fill my sewing space with inspiring images, like a pretty sewing machine cover! I hope this illustrated cover inspires you and protects your best friend from dust, as well.



# Instructions

Seam allowances are  $\frac{1}{4}$ " unless otherwise noted.

## APPLIQUÉ AND STITCH THE DESIGN

1. Refer to Techniques (page 10) to stitch the design onto the  $14\frac{1}{2}$ "  $\times$  21" linen rectangle. Place the bottom of the stitched illustration 1" above a  $14\frac{1}{2}$ " side of the rectangle. You can use the Sewing Room pattern (page 99) or another pattern of your choice. I used a 2.0 stitch length for this design. The slightly longer stitch length works with this design because the simple squares and big motifs are easier to sew. *Fig. A*

2. Repeat Step 1 to appliqué the Knitting Chick pattern (page 107) or another pattern to the 3"  $\times$  3" white solid square.

## MAKE THE COVER

1. Sew 14 of the  $1\frac{1}{2}$ " assorted print squares together to make a  $1\frac{1}{2}$ "  $\times$   $14\frac{1}{2}$ " row. Make 3 rows. Join the rows together to make 1 rectangle  $3\frac{1}{2}$ "  $\times$   $14\frac{1}{2}$ ". *Fig. B*

2. Repeat Step 1 to make 1 additional pieced rectangle.

3. Stitch a print 2 strip to each end of the linen rectangle.

4. Add a pieced print rectangle unit to each end of the linen rectangle. *Fig. C*

5. Press the fusible interfacing to the wrong side of the lining, following the manufacturer's instructions. Sew the lining and cover together, right sides together. Leave a 3" opening in one side for turning. *Fig. D*



6. Turn the cover right side out, gently poke out the corners, and press. Close the opening with hand stitching. *Fig. E*



7. Place the fusible side of the 3" square of interfacing facedown on the front of the 3" Knitting Chick square and sew around all 4 sides. Make a 1" slit on the fusible interfacing and turn the unit right side out. Center the square on the other side of the cover and fuse into place. Hand stitch the edges using appliqué thread and a needle. *Fig. F*



8. Topstitch all the way around the outside of the cover. *Fig. G*

• **TIP** • Try using 12-weight thread for a bold line. Change the needle to a size 90 and adjust the stitch length to 3, or use embroidery floss and stitch the design in a running stitch.



Humble Bundle

Pretty Sewing Machine Cover

# Rainbow Ribbons Mini Quilt

Finished quilt: 18¾" × 18¾"



## Materials and Supplies

See *Supplies* (page 8) for additional information and a full list of notions.

**Print scraps:** 9 squares at least 2½" × 2¼" for appliqué

**Assorted print scraps:** 48 scraps at least 2¼" × 2¼" for patchwork (I cut 2 squares from each of 24 prints.)

**White solid:** ¼ yard for block backgrounds

**Linen:** ¼ yard for borders

**Backing:** ⅝ yard

**Binding:** ¼ yard

**Cotton batting:** ⅝ yard

**Fusible web,** like Lite Steam-A-Seam 2

**Thread:** Dark wine (50-weight preferred) for stitched illustration and neutral (ivory) for construction

## Cutting

*The border strips are the exact length needed for the pattern. To allow for piecing variations, you may want to wait until you have finished the quilt center to cut the border strips for your quilt.*

**Assorted print scraps:** Cut 48 squares 2¼" × 2¼".

**White solid:** Cut 9 squares 4" × 4".

### Linen

- Cut 2 rectangles 2¼" × 15⅜".
- Cut 2 rectangles 2¼" × 18¾".

**Backing:** Cut 1 square 21" × 21".

**Binding:** Cut 2 strips 2¼" × the width of fabric.

**Cotton batting:** Cut 1 square 20" × 20".

Project photo by C&T Publishing

I have always loved hand-appliquéd quilts. I wondered how I could adopt my thread-drawing method to make a quilt as charming as traditional hand appliqué, so I came up with this ribbon motif. I'm very happy with the result; it looks like a butterfly but is a lot easier and quicker to stitch. You can use other small motifs from this book or mix and match different shapes and sizes of motifs to create your own design. I once made a pillow combined with various motifs, and it made the best housewarming gift for my dear friend.



*Rainbow Ribbons Mini Quilt* in an alternate colorway, made and quilted by Kristyne Czepuryk

# Instructions

Seam allowances are  $\frac{1}{4}$ " unless otherwise noted.

## APPLIQUÉ AND STITCH THE DESIGN

Refer to Techniques (page 10) to stitch the design onto 9 white solid 4" × 4" squares. You can use the Ribbons pattern (page 106) or another pattern of your choice. I used a 1.8 stitch length for this design. *Fig. A*



## ASSEMBLE THE BLOCKS AND ADD THE BORDERS

1. Sew together 2 print squares for the first row, which will be the top left corner of the quilt center. Sew the blocks together in diagonal rows, as shown below, referring to the quilt photo (next page). Press the seam allowances of each row in alternating directions. *Figs. B & C*



2. Sew the rows together to make the quilt center. Press the seams as desired. Trim each side by lining up the  $\frac{1}{4}$ " mark on your ruler with the tip of the white ribbon blocks and cutting. Check the cutting lines first with a large square acrylic ruler, if you have one. If your trimmed square does not measure  $15\frac{3}{8}$ ", adjust the size of the borders. *Fig. D*

3. Sew the  $2\frac{1}{4}$ "  $\times$   $15\frac{3}{8}$ " linen border strips to the top and bottom of the quilt center; press the seam allowances toward the border. Sew the remaining border strips to the right and left edges of the quilt center to complete the quilt top. Press the seam allowances toward the border.

### FINISH THE QUILT

1. Quilt and bind (page 16) as desired. I quilted vertical and horizontal grid lines.
2. Draw a guideline  $\frac{1}{2}$ " outside the border seam, using a temporary fabric marker or Hera Marker. Topstitch by hand using 2 strands of embroidery floss to add character to the quilt. *Fig. E*



Alternate colorway, made and quilted by Kristyne Czepuryk

# Find Your Own Path Pillow

Finished pillow: 19" x 19"



## Materials and Supplies

See *Supplies* (page 8) for additional information and a full list of notions.

**Assorted prints:** 5 prints and 1 white solid for appliqué pieces and front accent strip

**Linen:** 20" × 20" for pillow front background

**Lining:** 20" × 20"

**Backing:** ½ yard for back

**Binding:** ¼ yard

**Cotton batting:** ⅝ yard

**Fusible web,** like Lite Steam-A-Seam 2

**Thread:** Dark gray (28-weight preferred) for stitched illustration and neutral (ivory) for pillow construction

## Cutting

**Assorted prints:** After cutting the appliqué pieces, cut several pieces 1¼" wide with varying lengths to total 19" when pieced together. (Mine were cut in this order: 1¼" × 8¼", 1¼" × 2¾", 1¼" × 3", 1¼" × 4¾", and 1¼" × 2¼".)

**Backing:** Cut 2 rectangles 14" × 19".

**Binding:** Cut 2 strips 2½" × 42".

**Cotton batting:** Cut 1 square 20" × 20".

Pillows are one of my favorite projects. To me, the front of a pillow is like a big canvas on which I can draw anything, and the final product fits anywhere in the house. One day I saw that my daughter had covered her bed with mama-made pillows and had set up a place to play with her dolls among them. It was a good reason to keep making more pillows.

For this pillow, I enlarged the sneakers pattern from *Find Your Voice* (page 76) by 200% to show you how small motifs can work for big projects. Try other motifs and make your own pillow—it will be a good practice for drawing with threads.





# Instructions

Seam allowances are  $\frac{1}{4}$ " unless otherwise noted. Measure your pillow insert and adjust the pillow size as needed.

## APPLIQUÉ AND STITCH THE DESIGN

Refer to Techniques (page 10) to stitch the design onto the 20" × 20" linen square. You can use the Find Your Own Path patterns (pages 78 and 79) or another pattern of your choice. The sneakers and wording patterns are separate, so you will need to arrange them on the pillow top. Place the wording at least 4" above the lower edge. I used a 1.8 stitch length for this design. Fig. A

## MAKE THE PILLOW FRONT

1. Sew the assorted print rectangles together end to end to make a strip. Press the seam allowances open.
2. Cut the linen square 3" from the bottom, and place the pieced strip in between the 2 linen pieces. Sew them together to finish the pillow front. Fig. B
3. Center and baste the pillow top, right side up, to the batting and lining using your preferred method. Quilt as desired. (I recommend using a walking foot.) I machine quilted straight lines  $\frac{1}{2}$ " apart. Trim off the excess batting and trim the pillow front to 19" × 19".

## MAKE THE PILLOW BACK

1. Fold one long edge of each pillow back rectangle under  $\frac{1}{2}$ " and press. Fold under  $\frac{1}{2}$ " again and press. Topstitch  $\frac{3}{8}$ " from the folded edge.



2. Place the quilted pillow front on a flat surface, right side down. Matching up the raw edges at the top of the pillow, place 1 backing rectangle faceup so the right sides of the back and front are together. The folded edge will run across the center of the pillow. Place the second backing rectangle with the raw edges aligned with the bottom of the pillow top. The folded backing edges will overlap at the center. Pin or clip all around.

## FINISH THE PILLOW

Bind the pillow using your favorite binding method (page 16).



# STITCHES AND PATTERNS



*Away*

I wanted to provide a variety of illustrations from our perfectly imperfect everyday scenes. Kids, Christmas, coffee breaks, and flowers on the pavement—those are the small but precious elements of life that you can sweetly stitch on any project. I hope this book will be well worn, with page corners turned down, notes written in the margins, and coffee stains dried on the pages. But most of all, I hope to see you and your sewing machine singing together.

*See Appliqué and Stitching (page 11) to download and print all the patterns and the reverse orientations.*



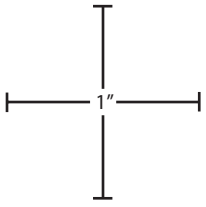

# Dear Diary

Just Begin





just  
begin

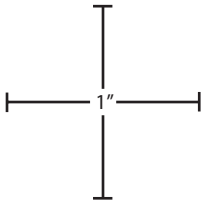

## I Choose Today





I choose **today**

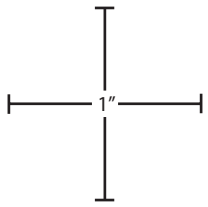

Stay True





STAY *true*



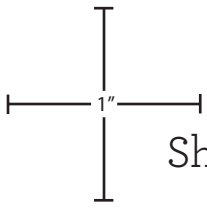

Shine Your Light



Shine your light

A string of colorful lights and fabric tassels hanging below the text. The string features a variety of items: a pink floral tassel, a solid pink light, a multi-colored tassel, a solid green light, a multi-colored tassel, a solid pink light, a multi-colored tassel, and a solid blue light.

THE SECRET OF GETTING AHEAD  
IS GETTING Started

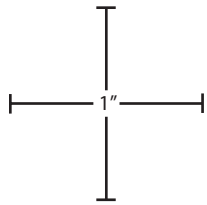

THE SECRET OF GETTING AHEAD  
IS GETTING Started



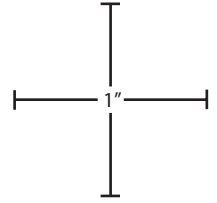

# Spring Has Sprung



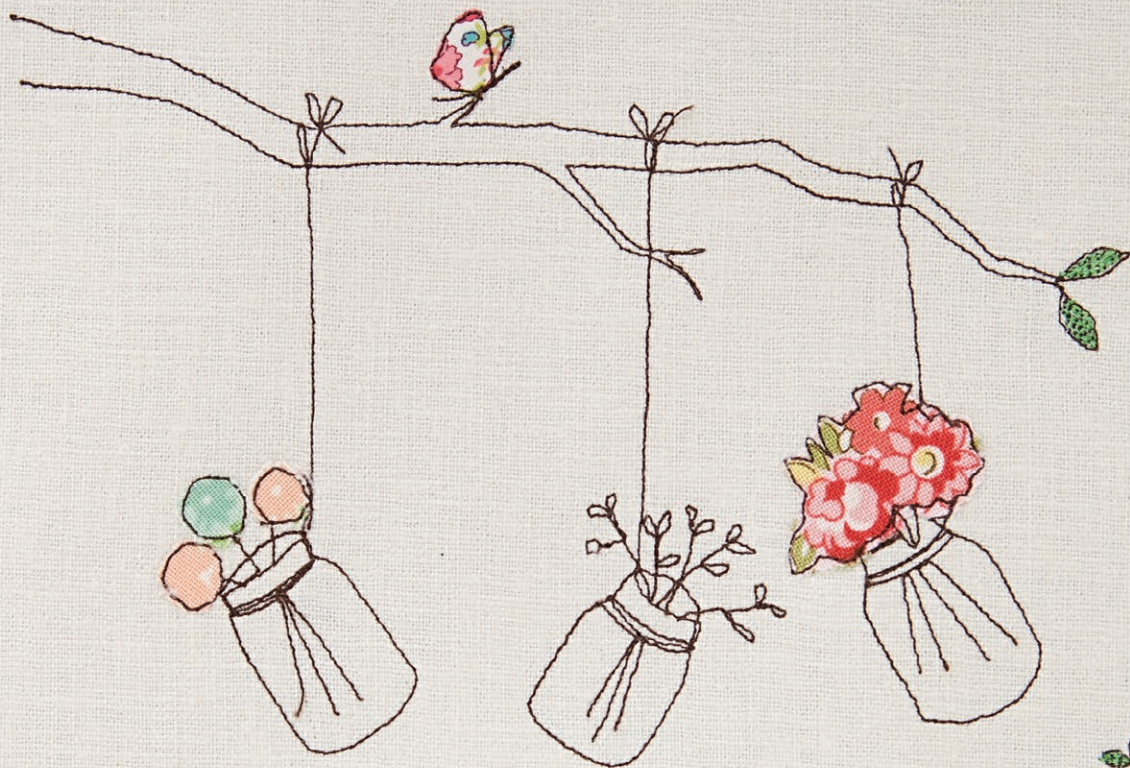

Spring  
has sprung

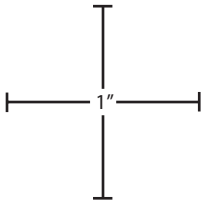

Life with You Is Always a Picnic

life with you  
is always  
A PICNIC

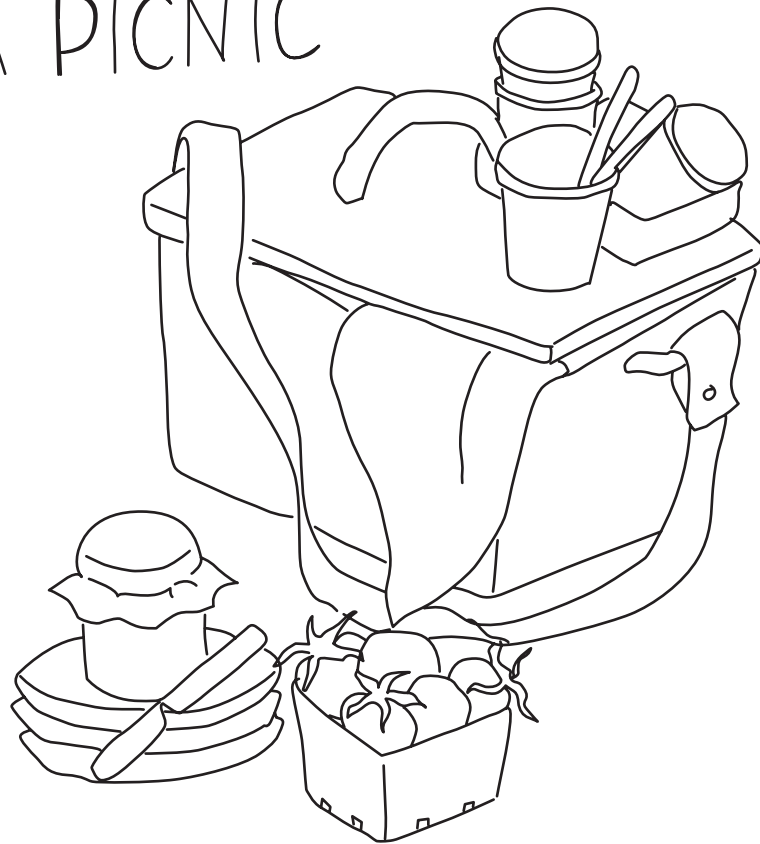

life with you  
is always  
A PICNIC





Add a Whole Lot of Love  
to Everything You Create

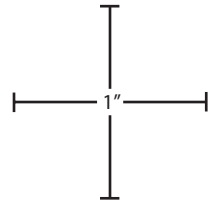

Add a whole lot of  
LOVE to everything  
You Create



Add a whole lot of  
LOVE to everything  
You Create



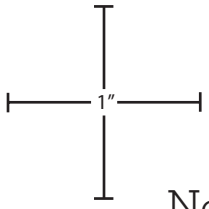

No Place like Home





NO PLACE

*like home*

Begin Each Day with a Grateful Heart

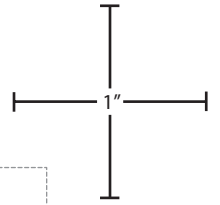

Begin each day  
with a grateful  
heart



Begin each day  
with a grateful  
heart



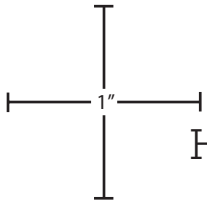

Hooray It's Today



HOOORAY

It's TODAY!





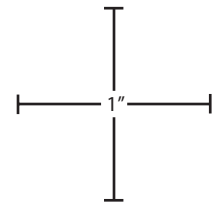

# Simple as That





SIMPLE *as that*

Little Moments

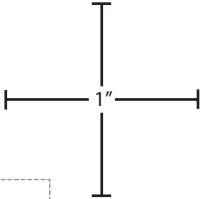



little moments

# Find Your Voice

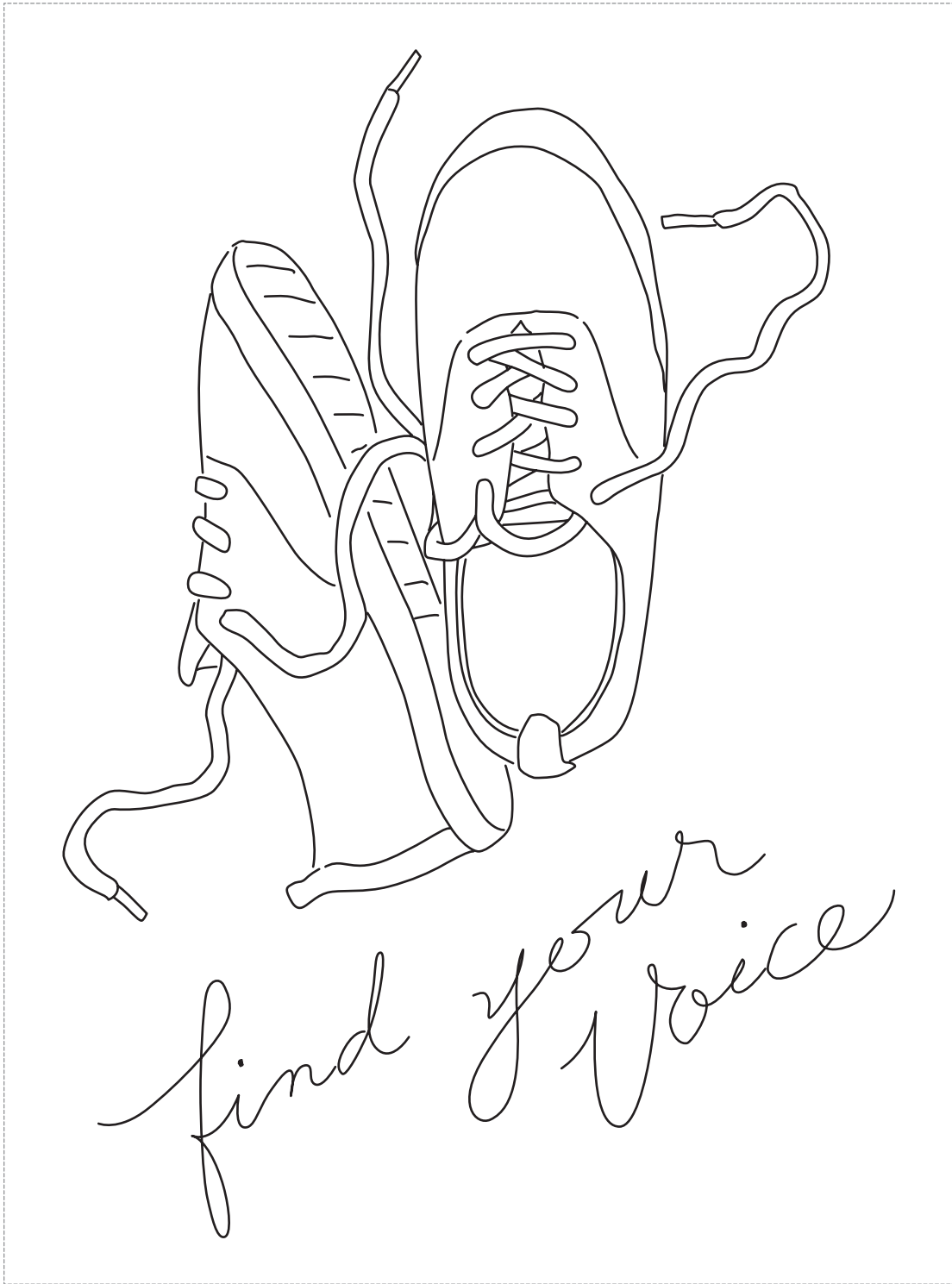
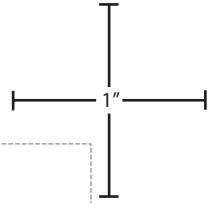



*find your voice*

# Find Your Own Path

This pattern is a 200% enlargement of the sneakers from Find Your Voice (page 76) and was used for the Find Your Own Path Pillow (page 46).

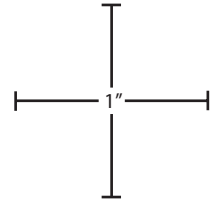
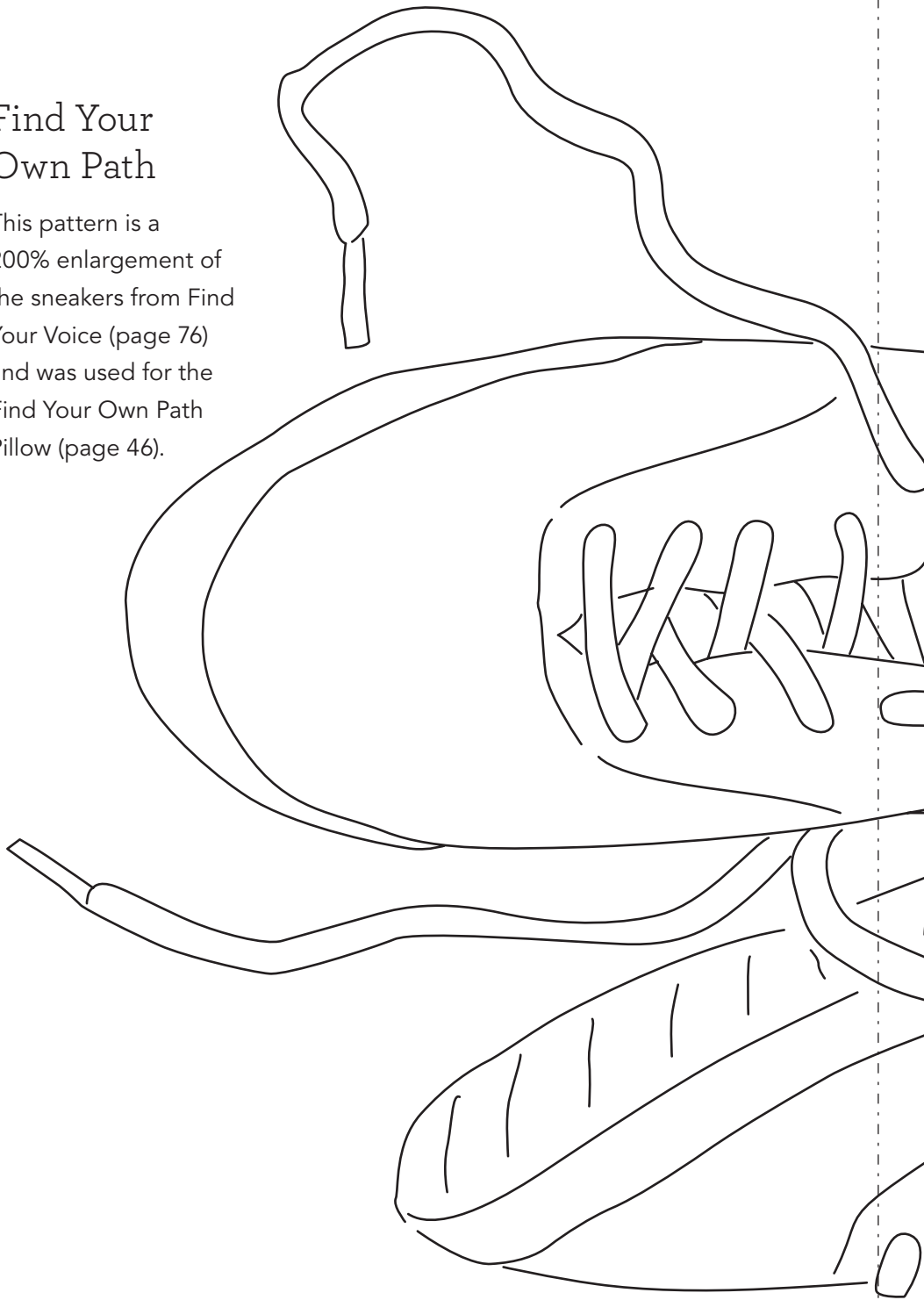

Tape here.

Tape here.

Tape here.

Tape here.

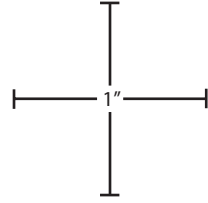
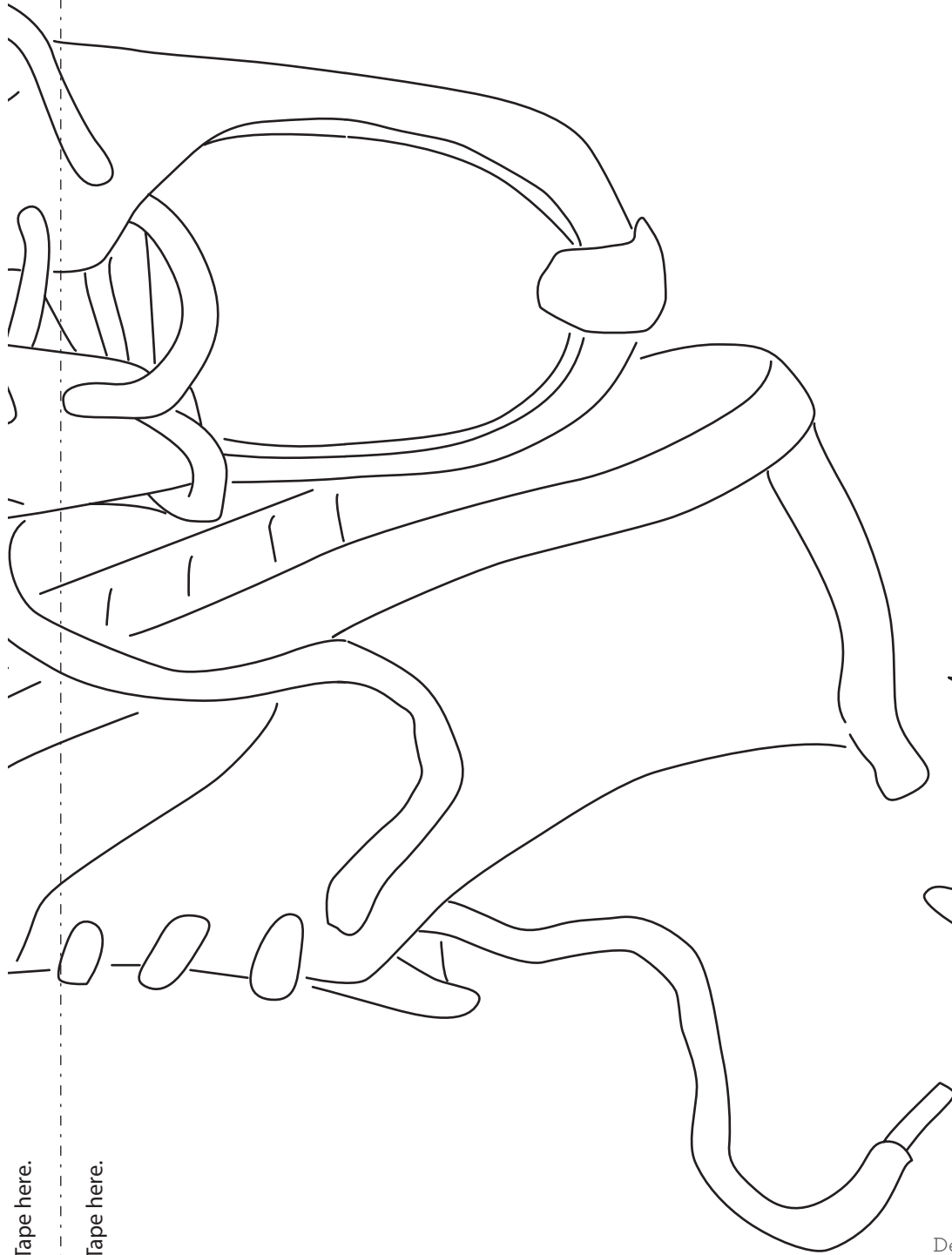

*find your own path*



# Good Things Happen When You Go for It

GOOD THINGS HAPPEN  
WHEN YOU GO FOR IT

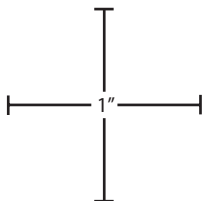

GOOD THINGS HAPPEN  
WHEN YOU GO FOR IT



# Thank You

See the project idea (page 121).

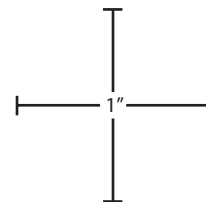



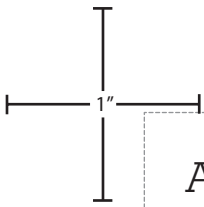

## Away

See the project idea (page 122).

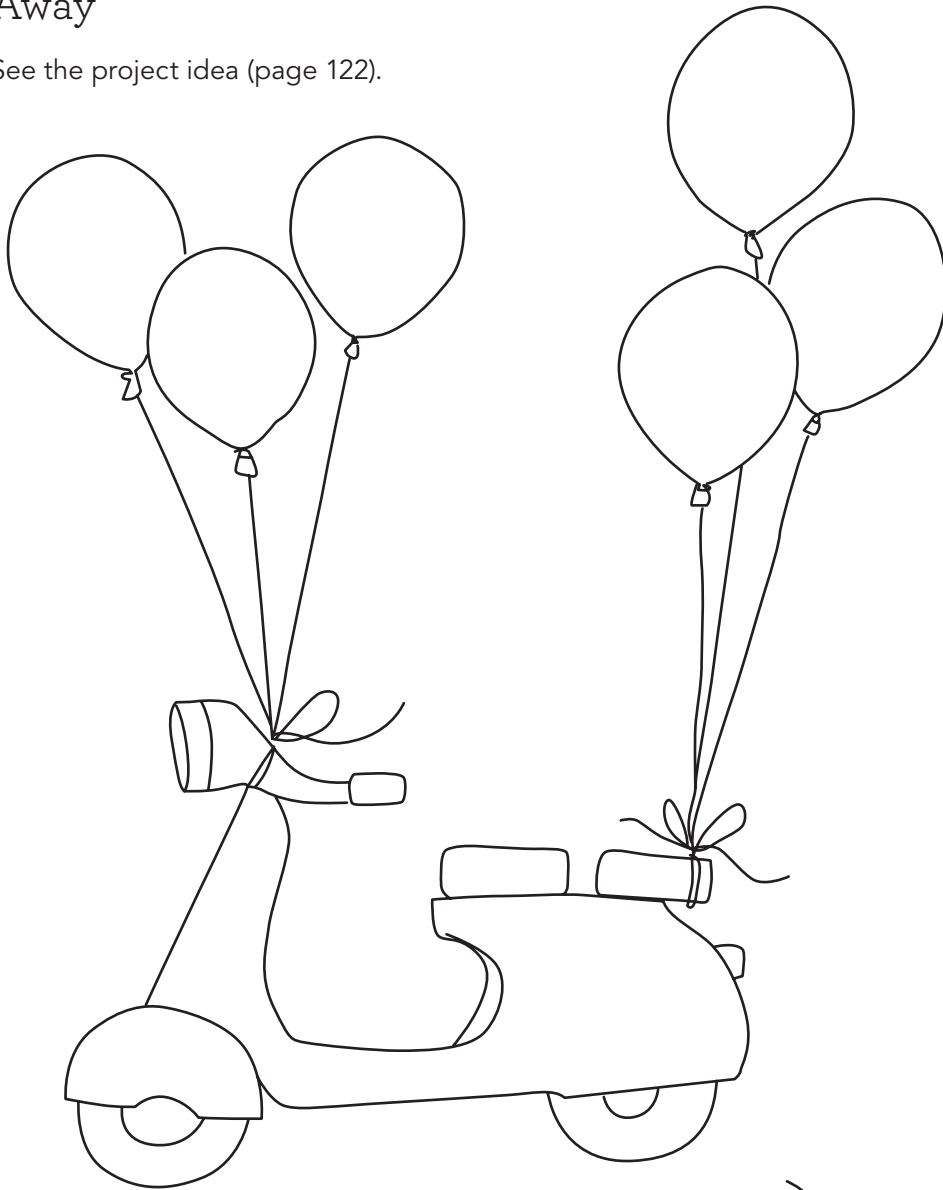

*Away*



Away

# A Girl with Bunny 1

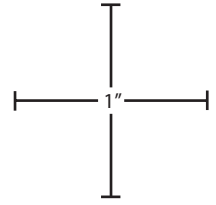





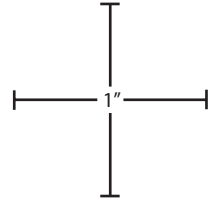

## A Girl with Bunny 2

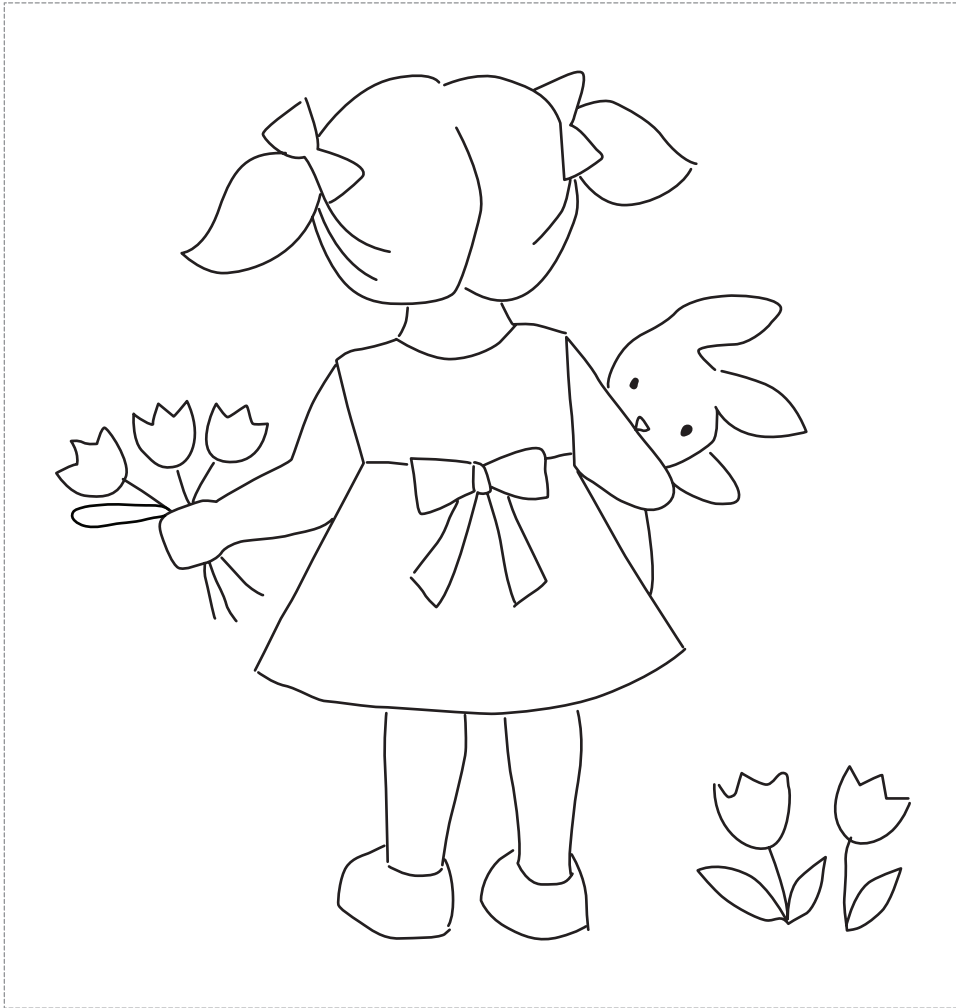



# Flower and Wreath Hanging

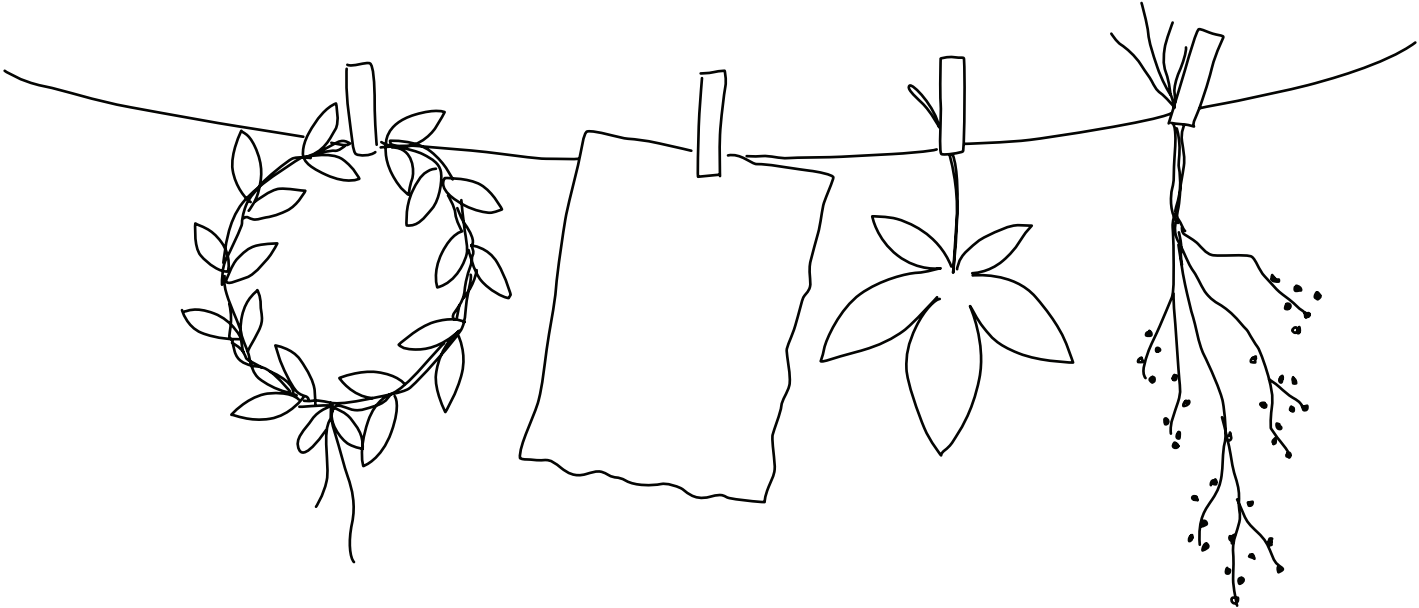
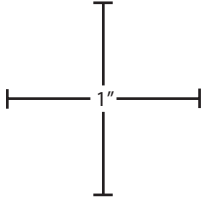



# You Are Loved

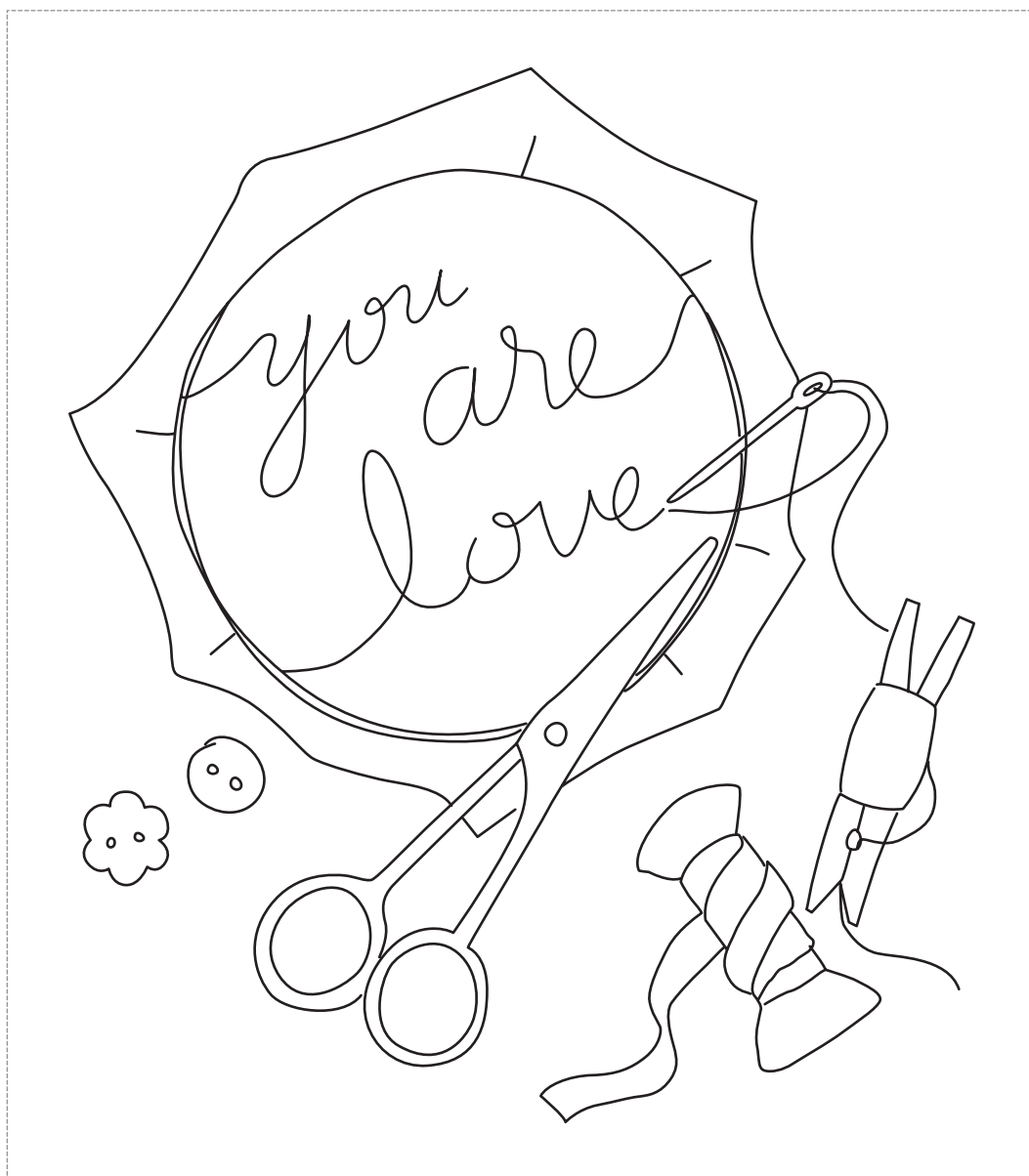
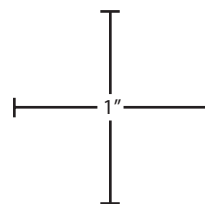



## Little Girl with Bear and Bunny

See the project idea (page 121).



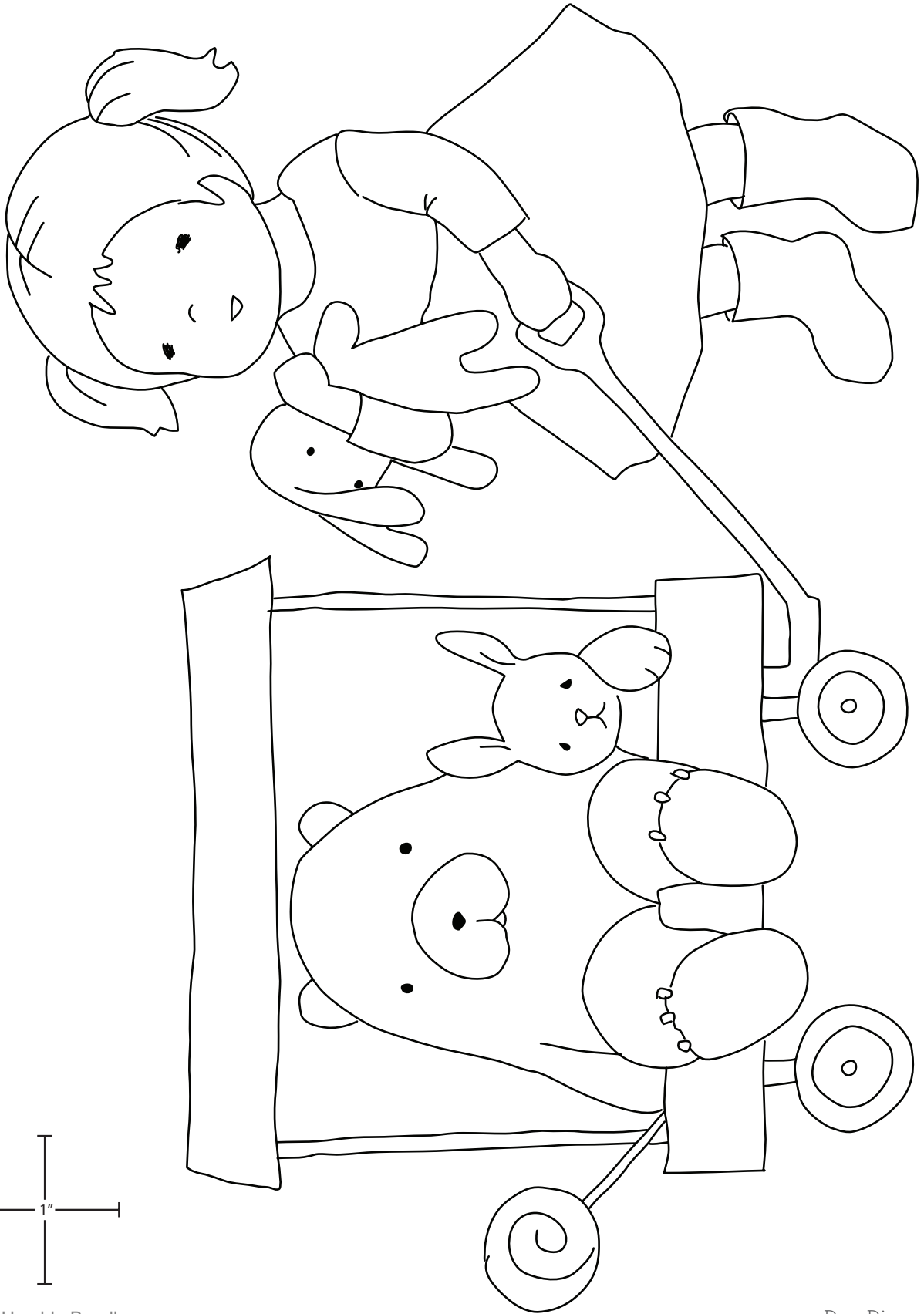



# Sweet Note

This pattern was used for the front of Sweet Notes Wall Pocket (page 33).

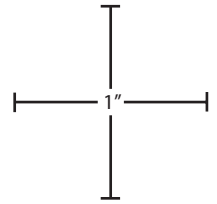



## Sewing Room

This pattern was used for the front of Pretty Sewing Machine Cover (page 38). See Knitting Chick (page 107) for the pattern used for the back of the sewing machine cover.



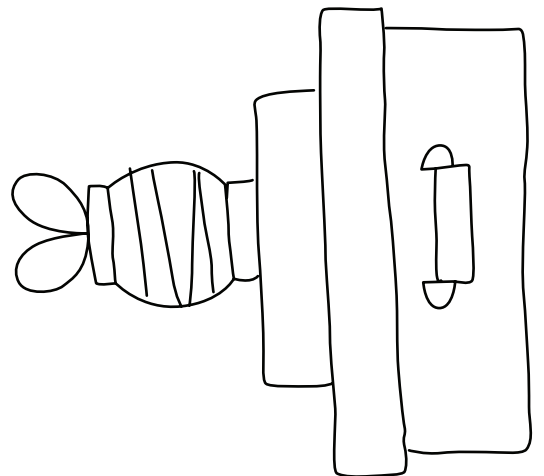
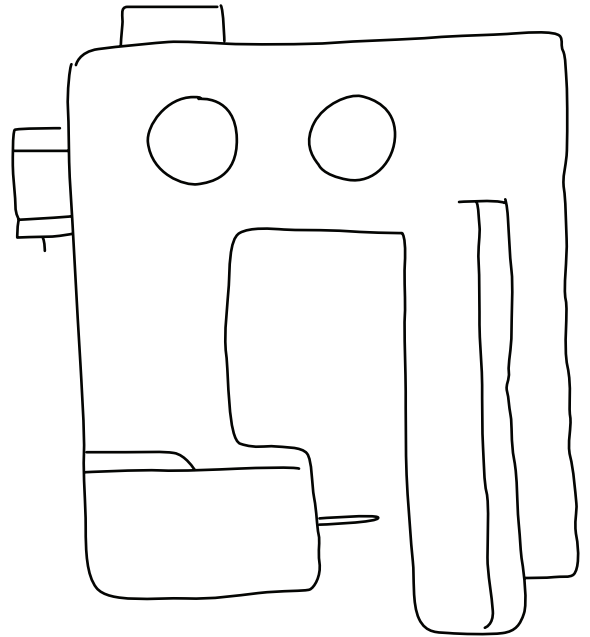
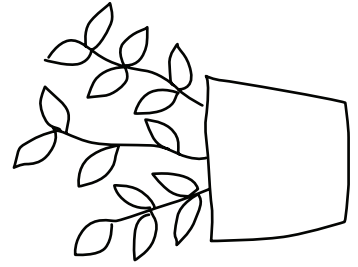
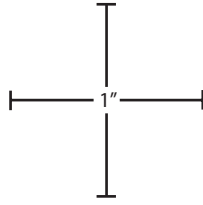
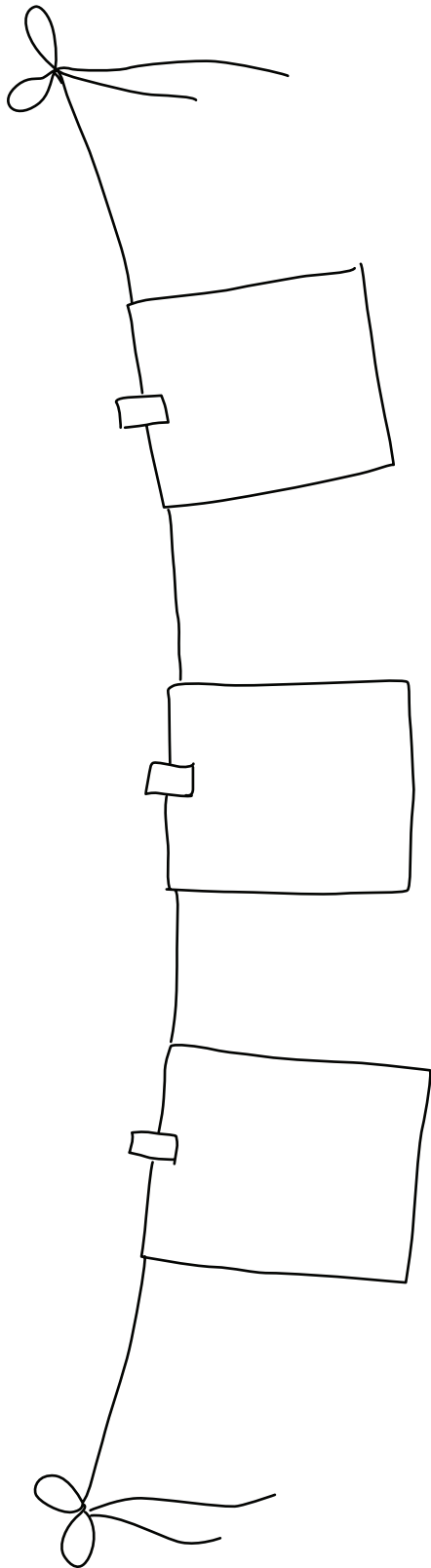

## Medium Motifs for a Special Day

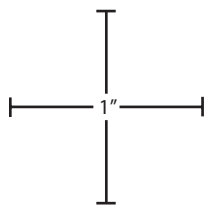

### Scissors and Spool

This pattern was used  
for the front of Darling  
Sewing Case (page 25).

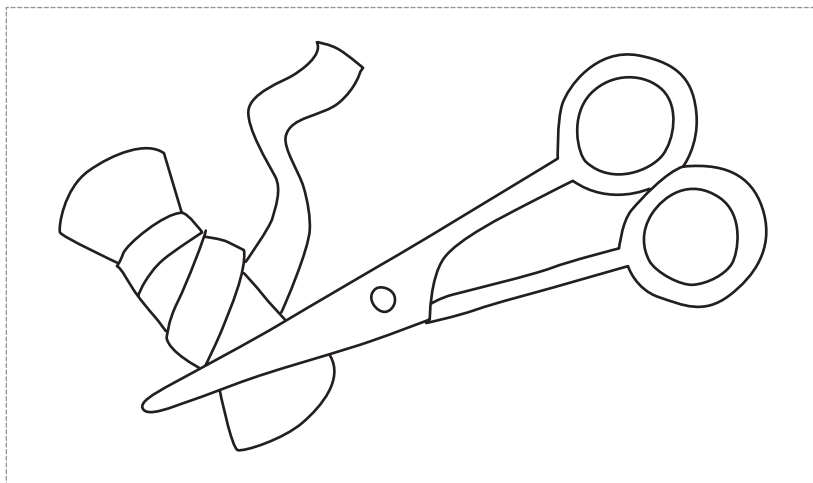

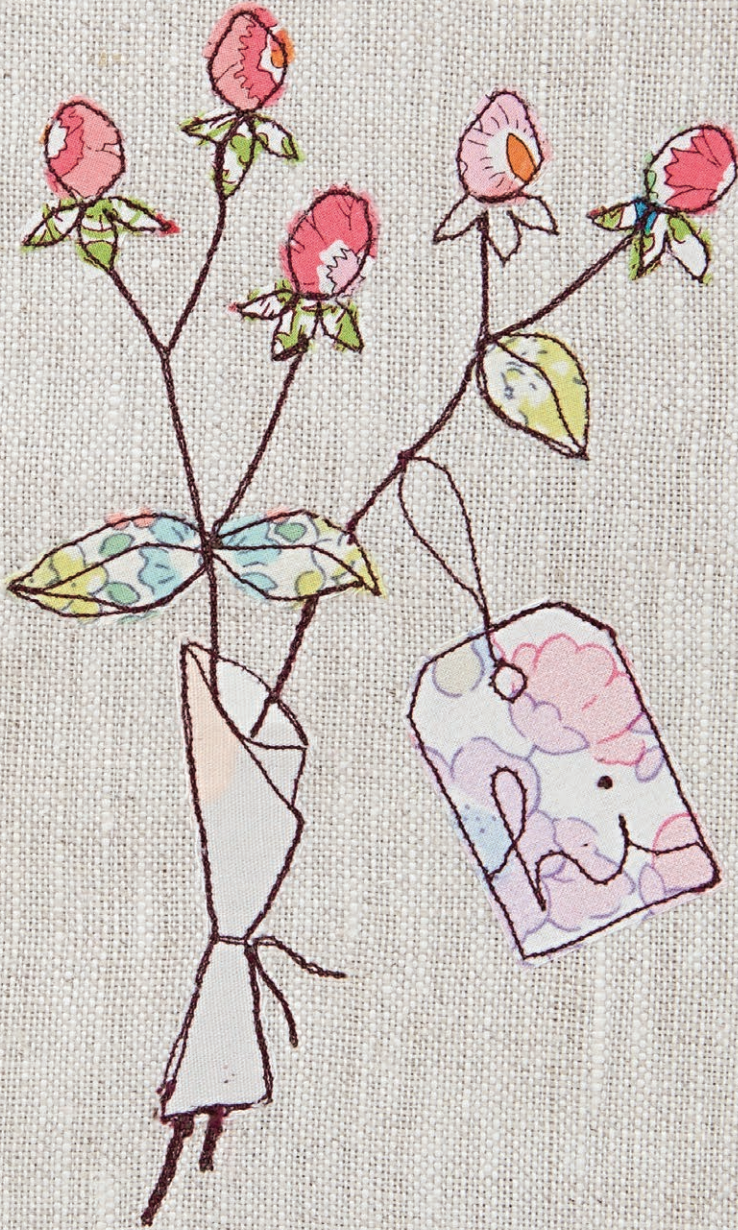

## Flower Bouquet

See the project idea (page 122).

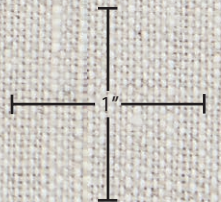
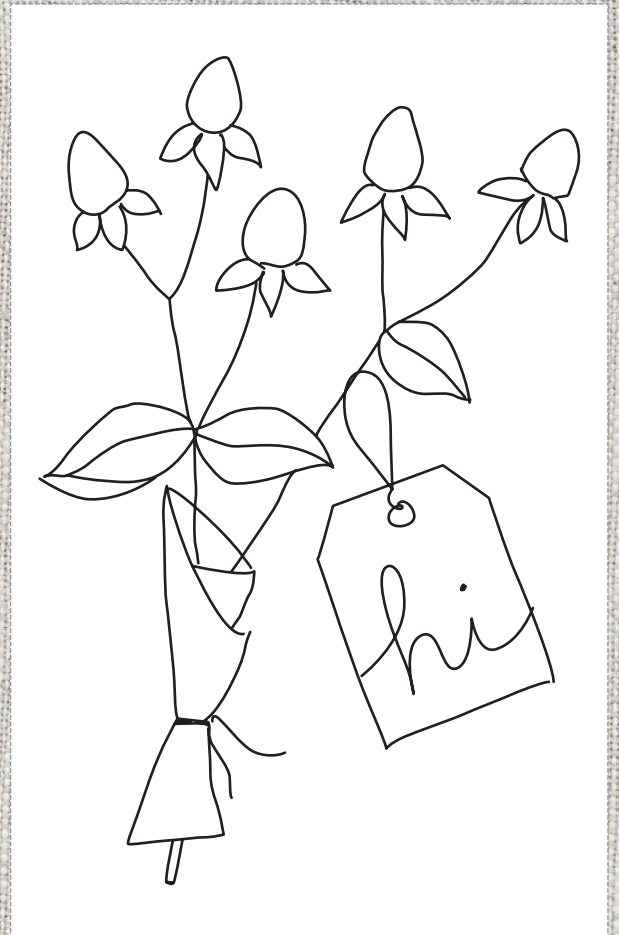

Love Ya

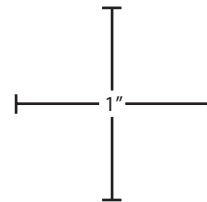





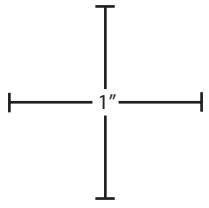

Just Begin  
Wording



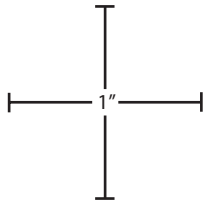

## We Have Each Other

See the project idea (page 123).

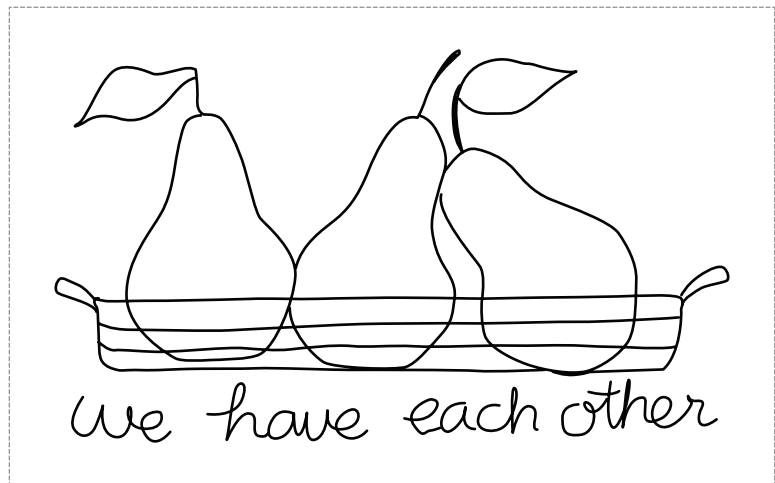

# Small Motifs for Every Day

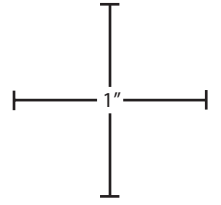

## Ribbons

This pattern was used in *Rainbow Ribbons Mini Quilt* (page 42). See the additional project idea (page 124).

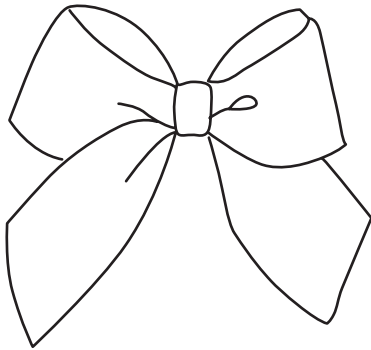

## Strawberry Bouquet

This pattern was used in the *Strawberry Zipper Pouch* (page 18). See the additional project idea (page 122).

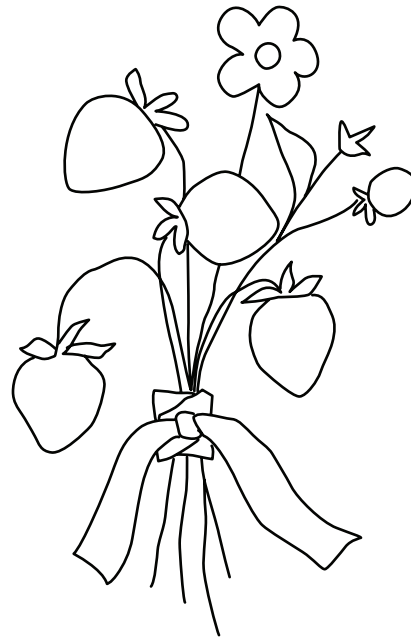

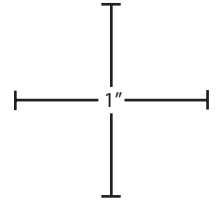

## Knitting Chick

This pattern was used for the back of Pretty Sewing Machine Cover (page 38).

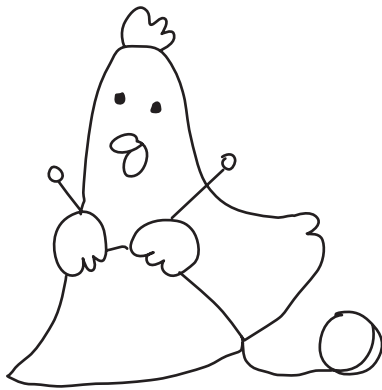

## Tulips

See the project idea (page 125).

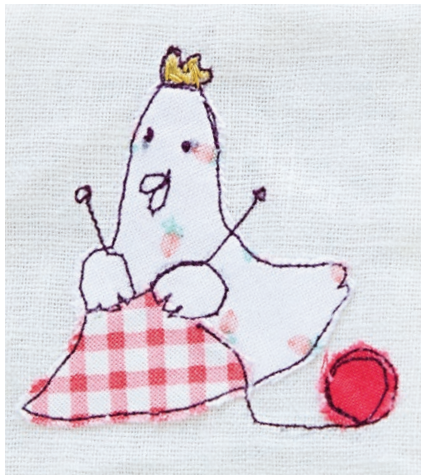
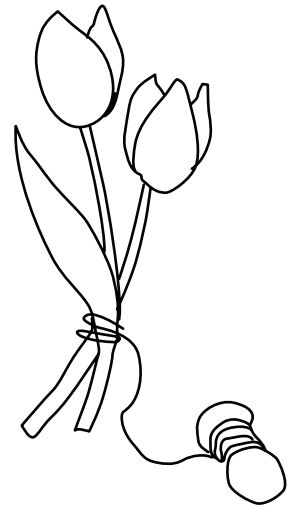
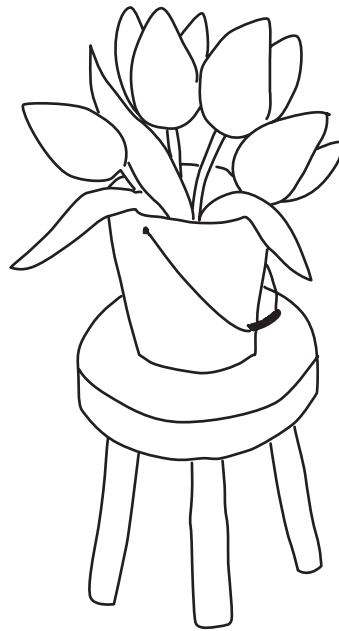

# My Kitchen

See the project idea (page 126).

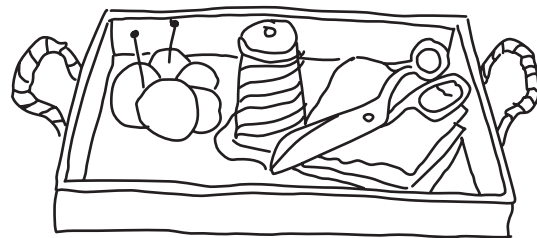
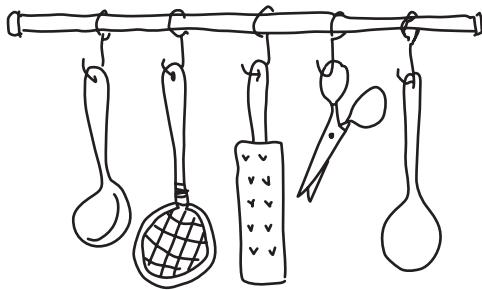
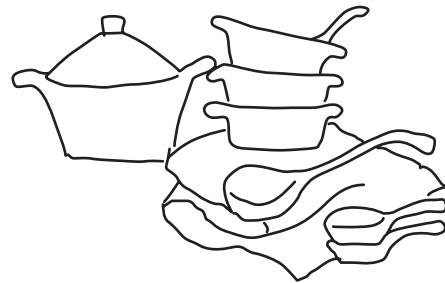
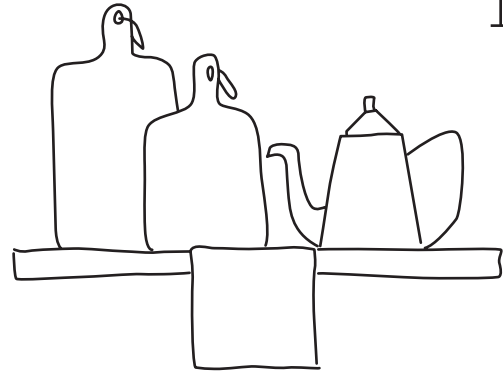
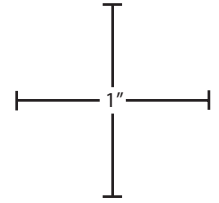

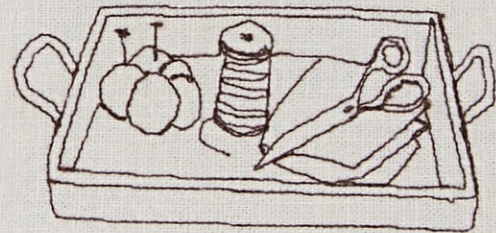
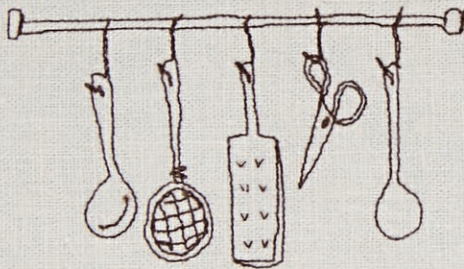

# Rain Boots

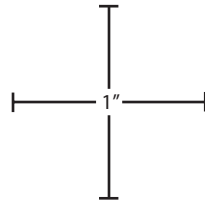

# Flower in a Bottle

See the project idea (page 120).

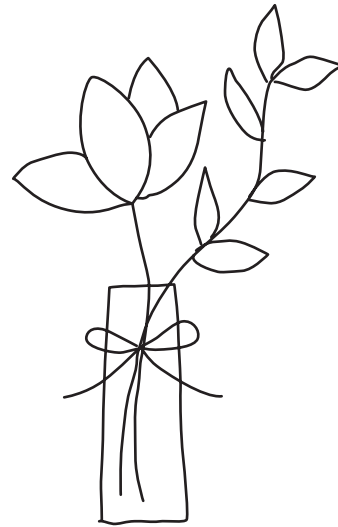

# More from My Kitchen

See the project idea (page 126).

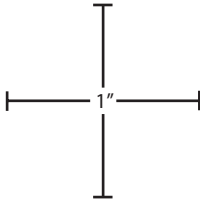
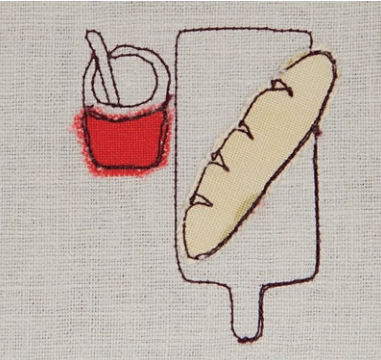
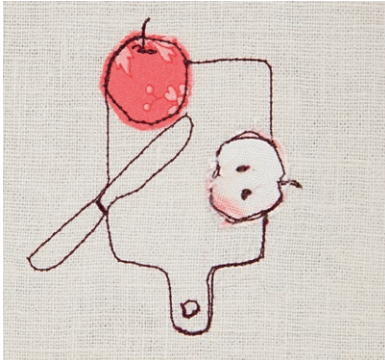
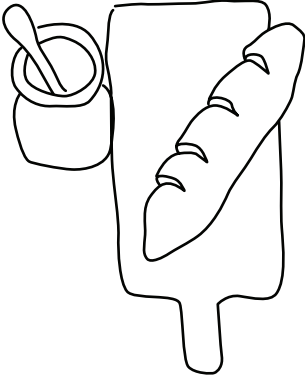
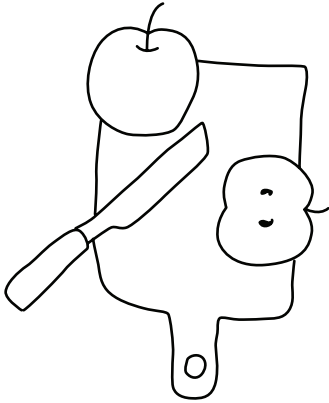
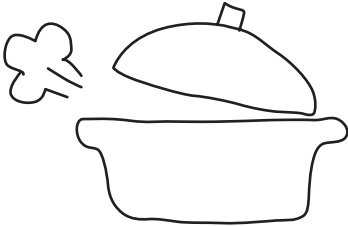



# Hoops for Home

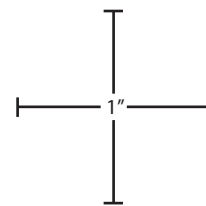

## Duck and Bird Hoops

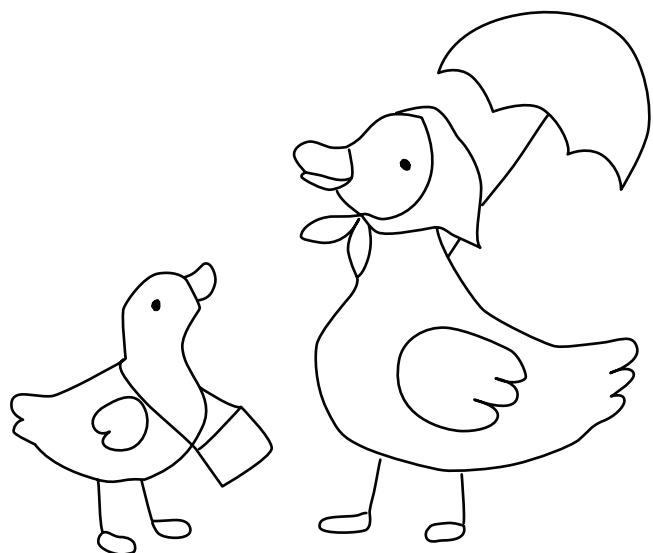
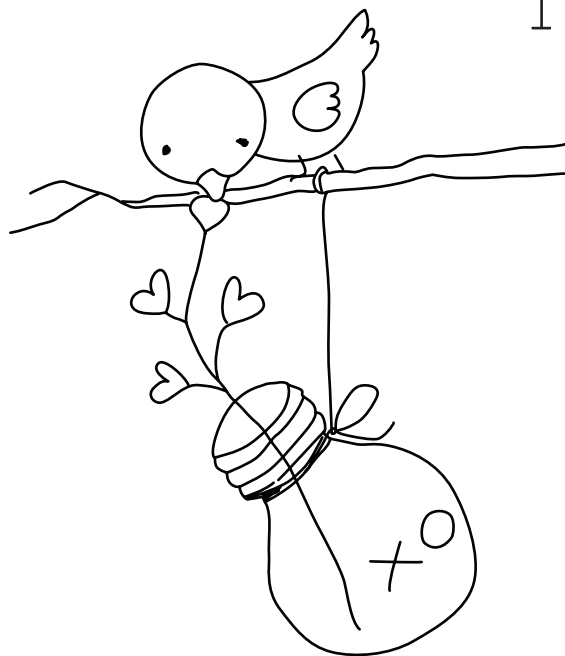
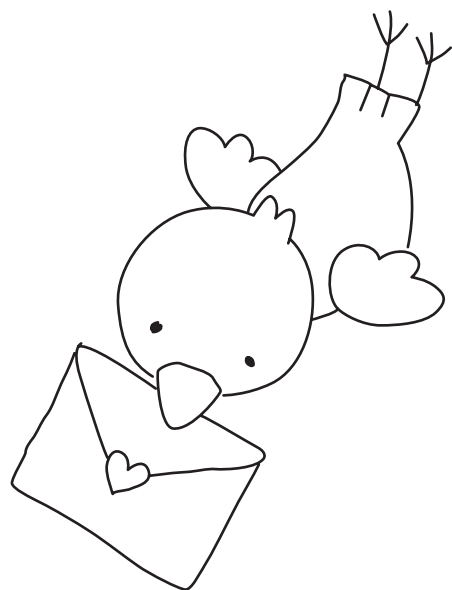



Mini Hoops

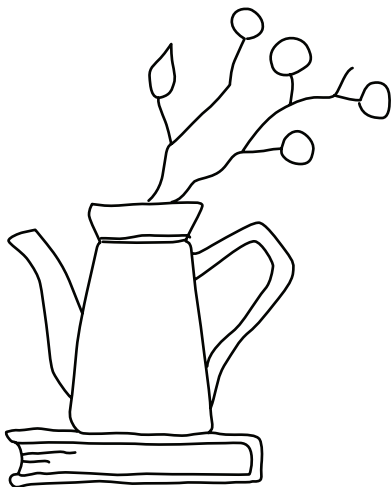
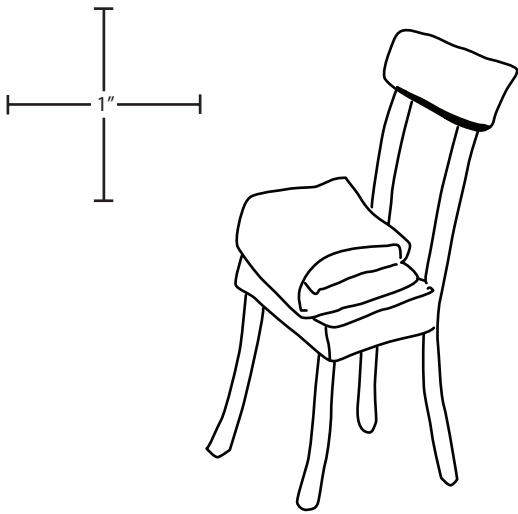



## House Hoops



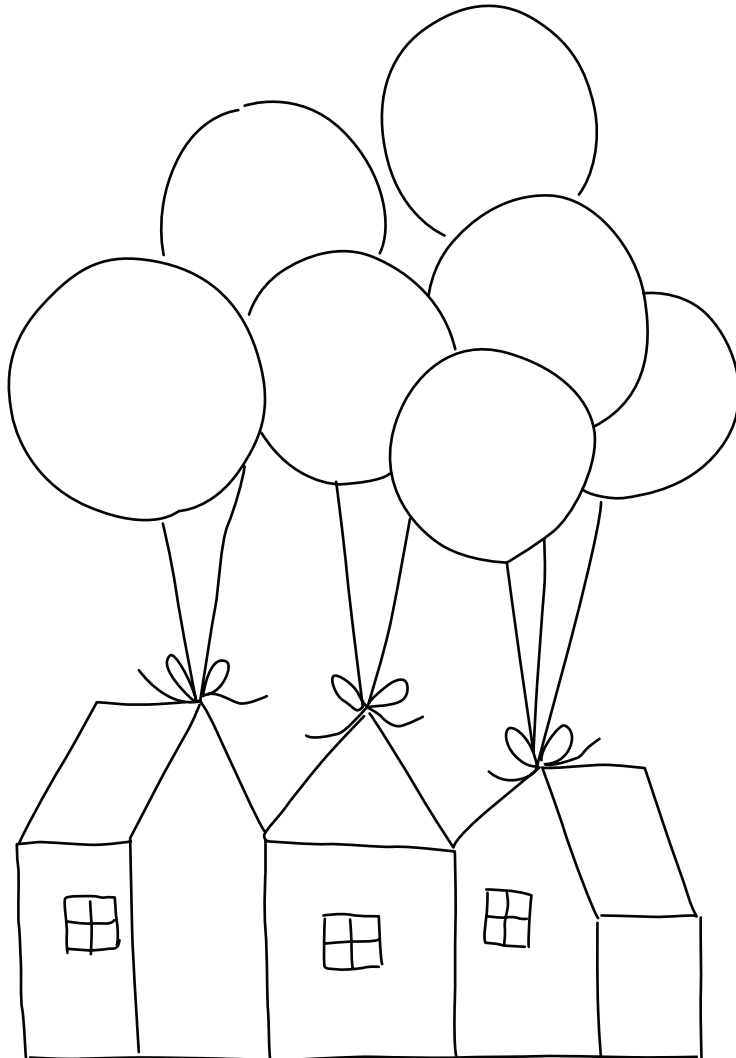
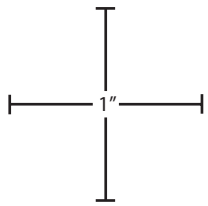

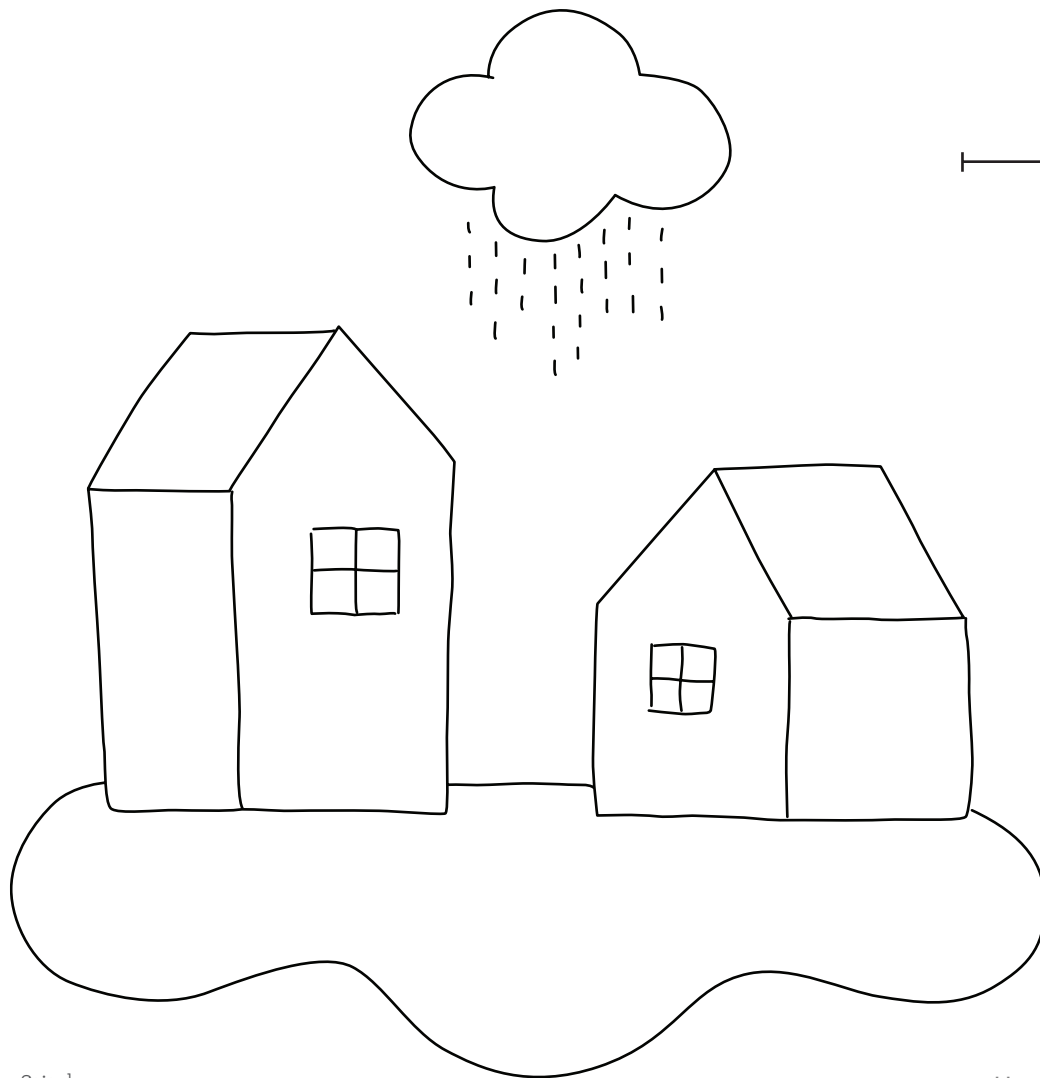

# Stitched Christmas

## Snowman

See the project idea  
(page 124).

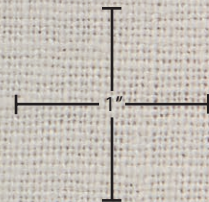

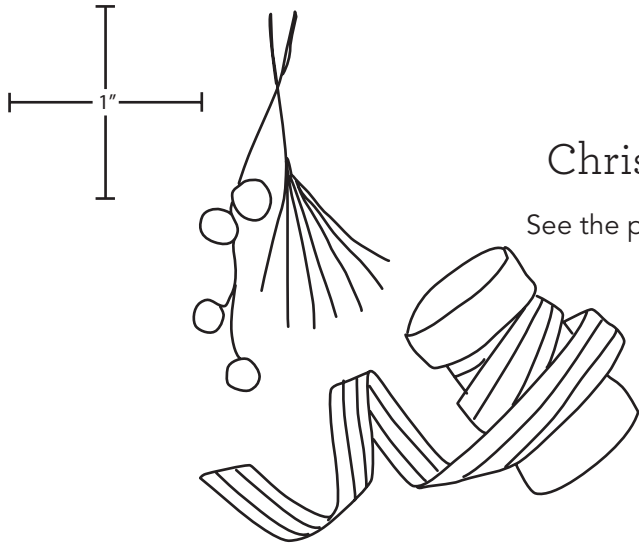

## Christmas Wishes

See the project idea (page 124).

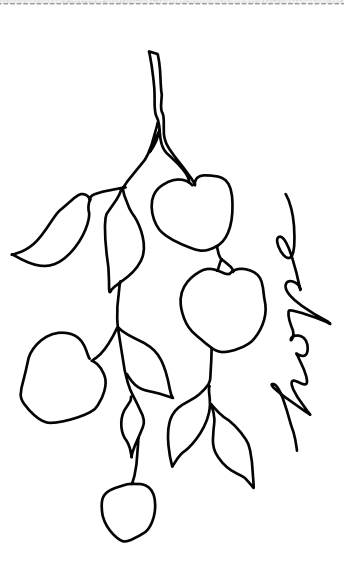
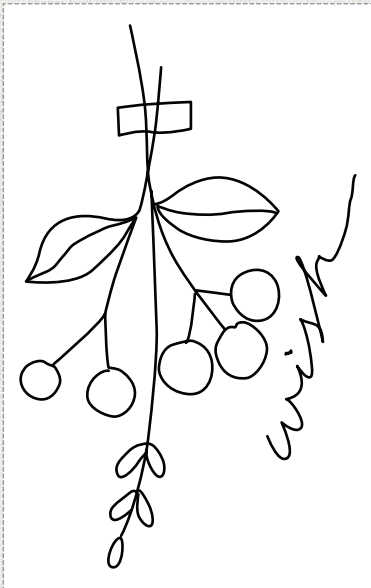
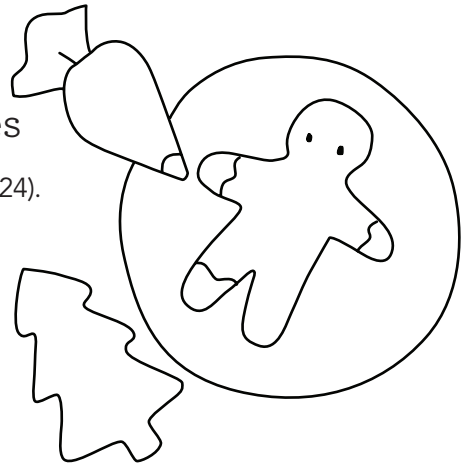

## Doggy with Gift Boxes

See the project idea (page 126).

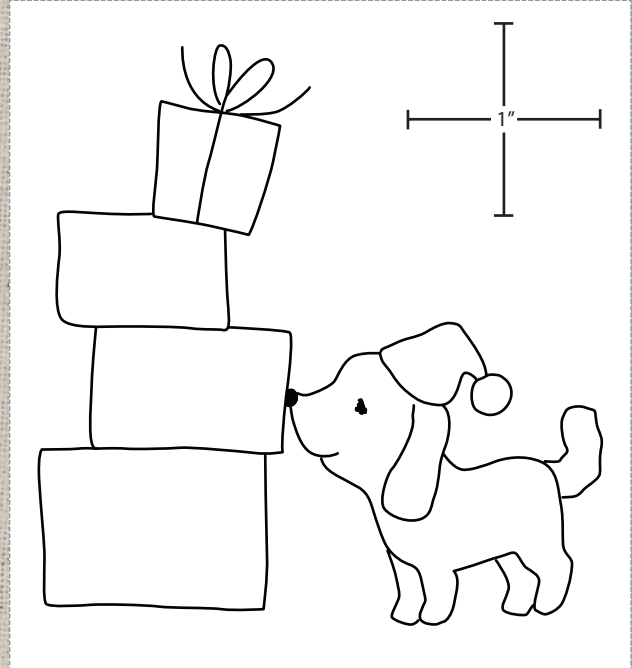

## Christmas Stockings

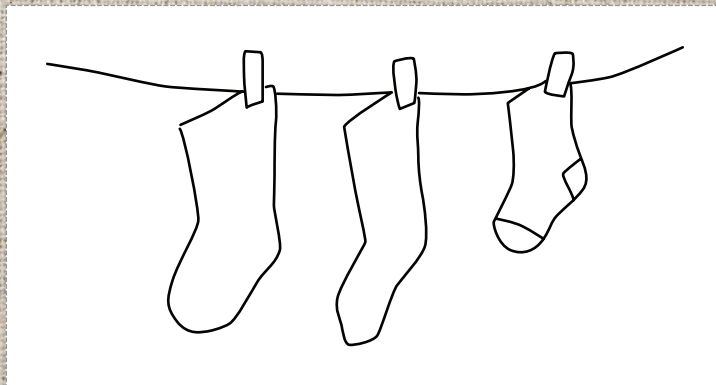



# Gallery of Project Ideas

With my sewing machine, I stitched a flower my daughter gave to me, a cradle holder my husband made, and my little girls' dolly play scene. I enjoy these unplanned adventures that always lead me somewhere. I hope you find joy in drawing with thread and turn your creations into something useful. For me, making bags, pouches, and pot holders gives life to my sewing illustrations. In this chapter, I would like to share some project ideas that will spark your imagination.

Flower in a Bottle  
Needle Case (page 110)





Thank You Mini Pillow (page 82)



A Girl with Bear and Bunny Play Mat (page 95): I enlarged the pattern to make this play mat.



Flower Bouquet Camera Pouch (page 101)



Away framed (page 84)



Strawberry Bookmark (page 106)



We Have Each Other Zipper Pouch (page 105)



Christmas Wishes  
Tea Mats—set of four  
(page 118)



Ribbon Pincushions (page 106)



Snowman Christmas Card (page 117)



Tulips Tea Mats (page 107)



Doggy with Gift Boxes Drawstring Bag (page 119)



Kitchen-Themed Patches Pot Holder (page 111):  
The small stitched squares show other motifs that could have been sewn to the pot holder.

My Kitchen Mini Quilt (page 108): For this project, I enlarged the patterns by 200%.



# About the Author



**Minki Kim** is a fabric and pattern designer with her own whimsical style. As a formally trained sculptor and self-taught sewist, she found that designing fabrics and creating art with fabric and thread were natural steps in her evolution as an artist.

Minki discovered sewing as a creative outlet when her children were small. She wanted to capture the beauty of ordinary moments, first with hand embroidery and later by recreating them with her sewing machine and fabric—literally drawing with thread. Capturing ordinary moments in beautiful sewing illustrations to make keepsake snapshots of daily life has become Minki's signature style.

Her first book, *Sew Illustrated—35 Charming Fabric & Thread Designs*, was coauthored with Kristen Esser and published by Stash Books, an imprint of C&T Publishing. Minki has also designed several fabric collections for Riley Blake Designs. Originally from Korea, she now calls Southern California home. She lives with her husband and three daughters.

*Follow Minki on social media:*

**Pattern website:**  
sewingillustration.com

**Blog:** minkikim.com  
(Be sure to check out Minki's tutorials link for how-to videos!)

**Instagram:** @zeriano

*Also by Minki Kim:*





Patterns from  
*Diary in Stitches*

Patterns from  
*Diary in Stitches*

# Just Begin

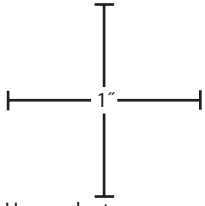

Use a ruler to measure these inch marks to verify that printout is correctly sized.

To make complete pattern, join the following pages, following the diagram for reference.

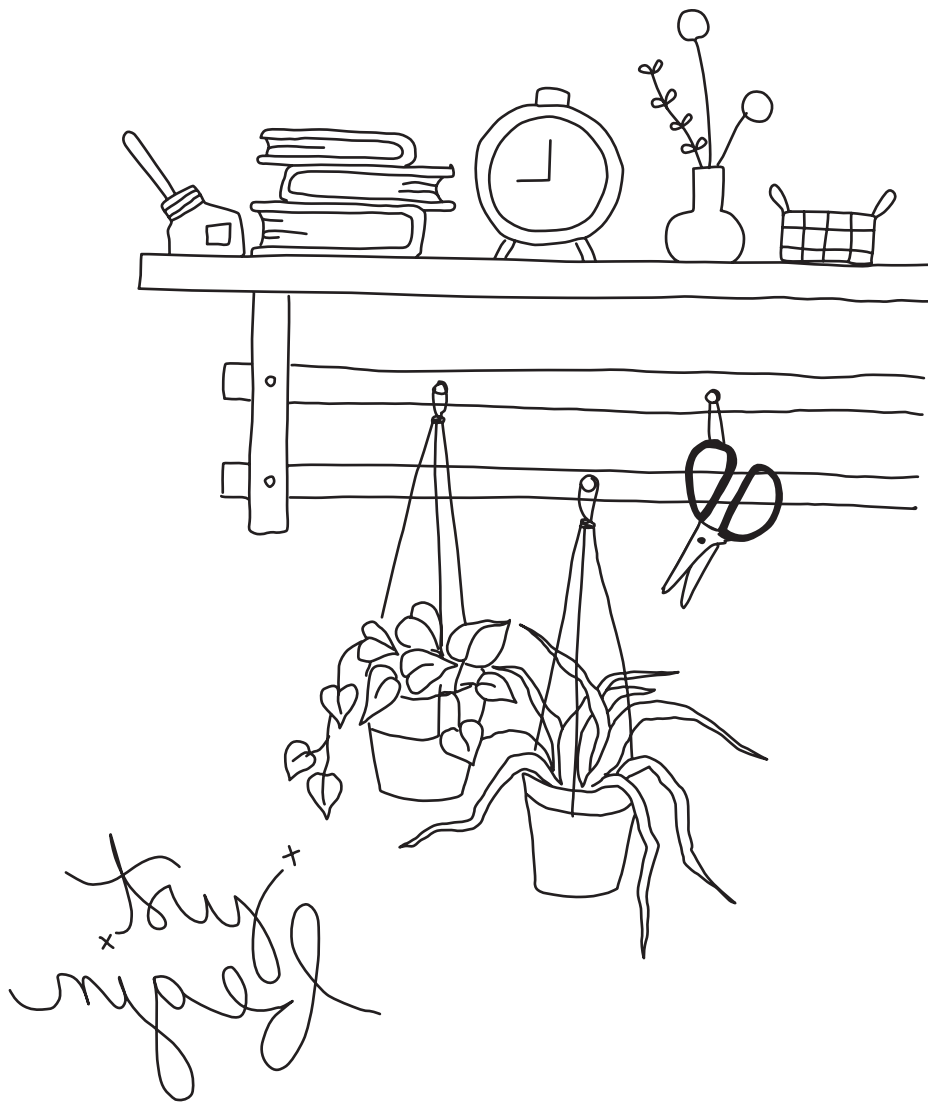

# Just Begin

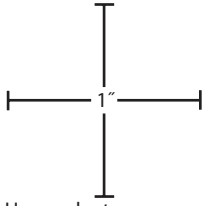

Use a ruler to measure these inch marks to verify that printout is correctly sized.

To make complete pattern, join the following pages, following the diagram for reference.

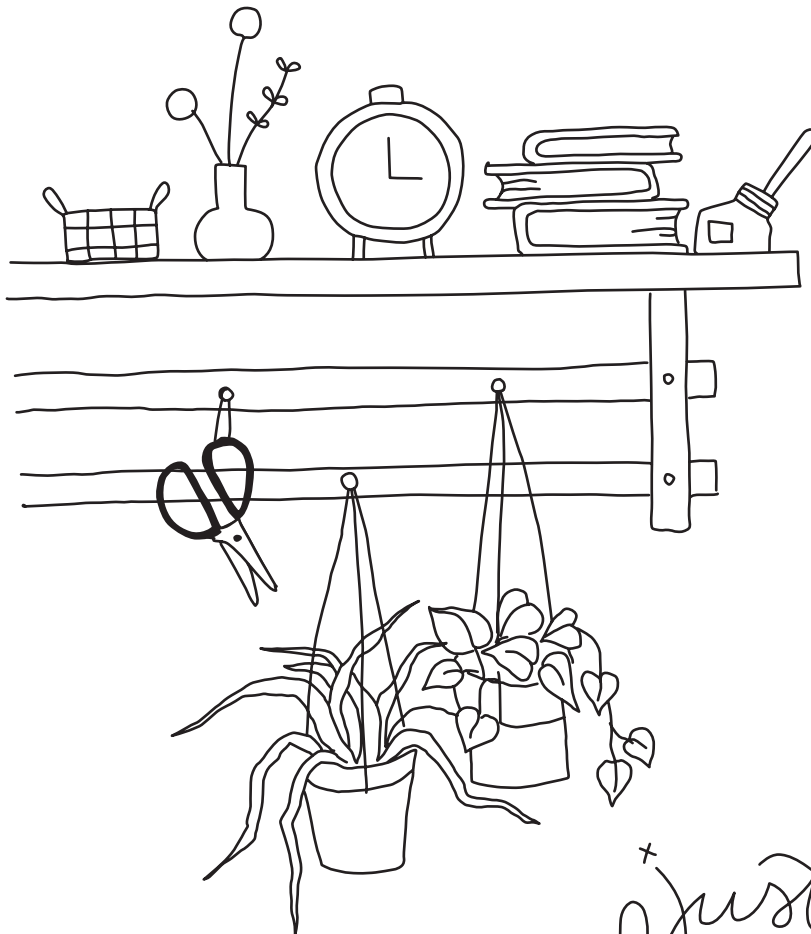

*just  
begin*

# I Choose Today

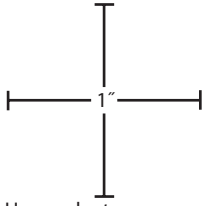

Use a ruler to measure these inch marks to verify that printout is correctly sized.

To make complete pattern, join the following pages, following the diagram for reference.

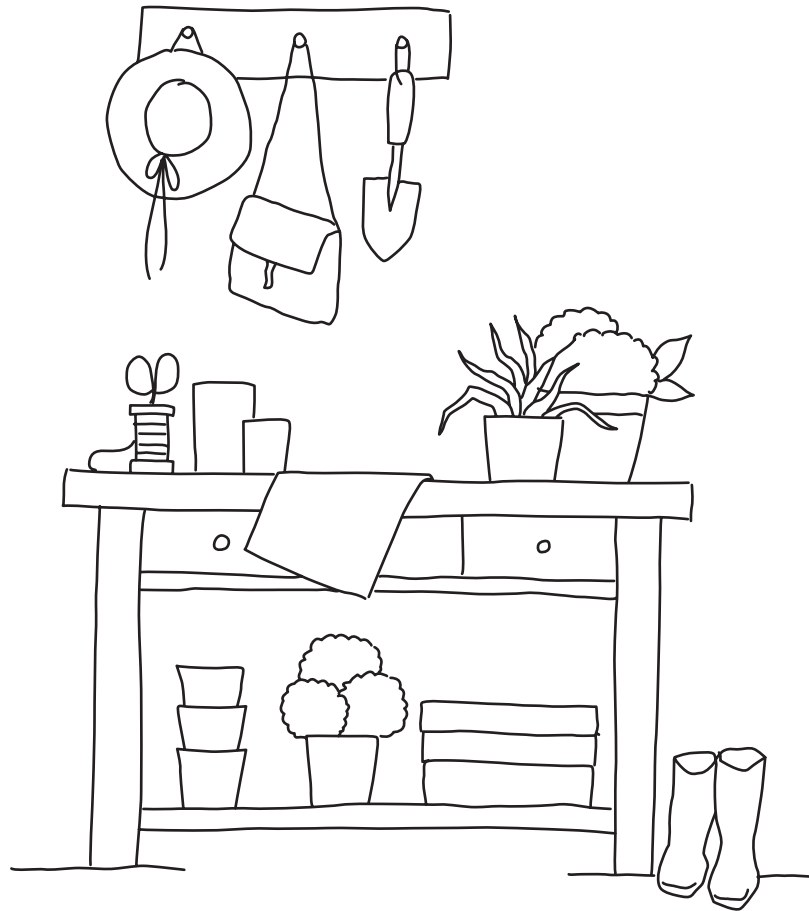

I choose today

# I Choose Today

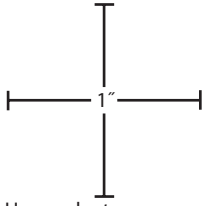

Use a ruler to measure these inch marks to verify that printout is correctly sized.

To make complete pattern, join the following pages, following the diagram for reference.



I choose *today*

# Stay True

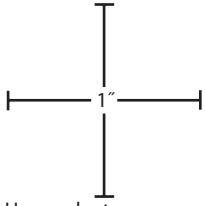

Use a ruler to measure these inch marks to verify that printout is correctly sized.

To make complete pattern, join the following pages, following the diagram for reference.

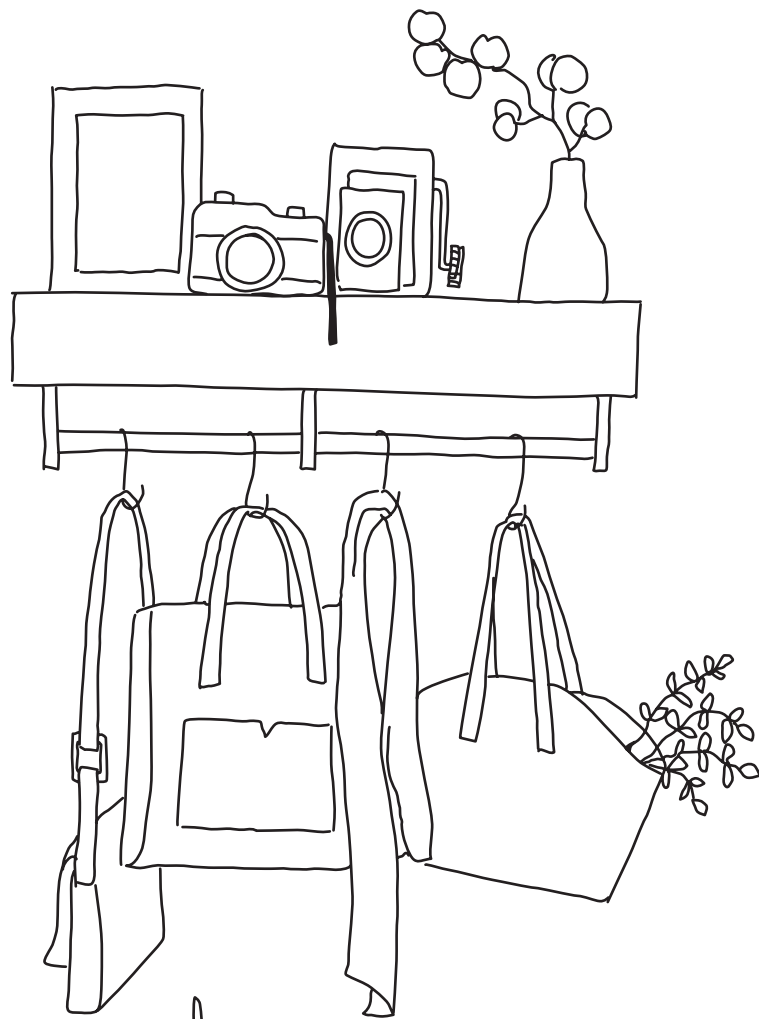

*YAT2* YAT2

# Stay True

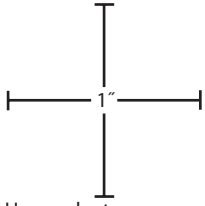

Use a ruler to measure these inch marks to verify that printout is correctly sized.

To make complete pattern, join the following pages, following the diagram for reference.

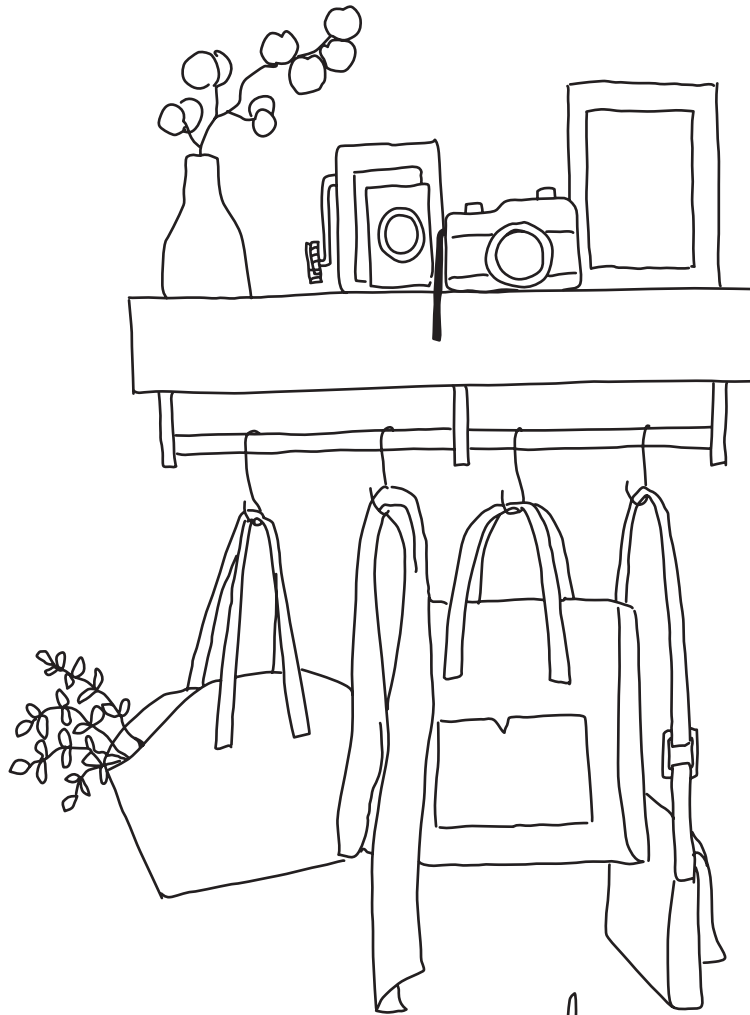

STAY *true*



# Shine Your Light

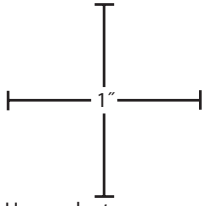

Use a ruler to measure these inch marks to verify that printout is correctly sized.

To make complete pattern, join the following pages, following the diagram for reference.

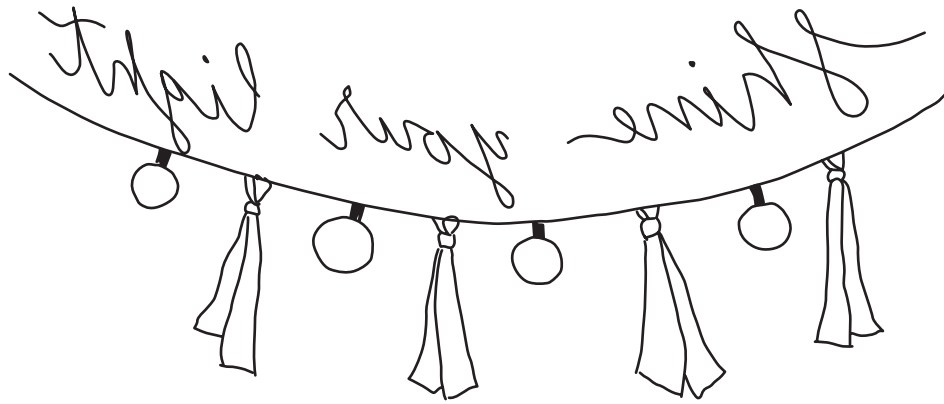

# Shine Your Light

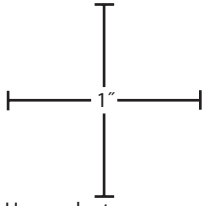

Use a ruler to measure these inch marks to verify that printout is correctly sized.

To make complete pattern, join the following pages, following the diagram for reference.



# The Secret of Getting Ahead

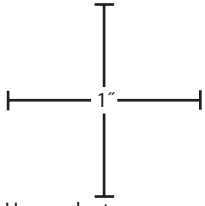

Use a ruler to measure these inch marks to verify that printout is correctly sized.

To make complete pattern, join the following pages, following the diagram for reference.

THE SECRET OF GETTING AHEAD  
is getting started

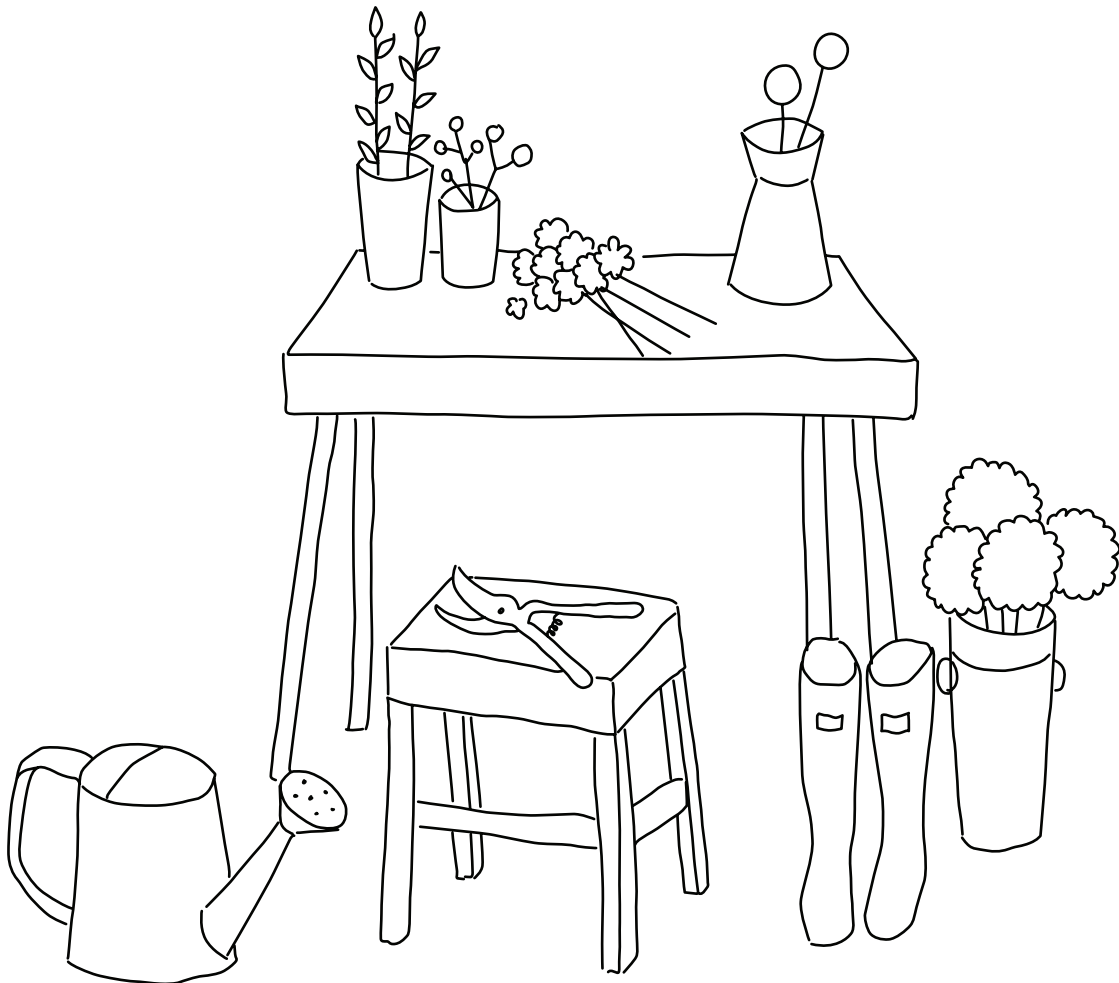

# The Secret of Getting Ahead

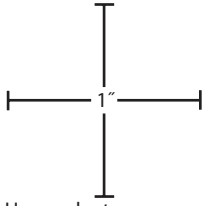

Use a ruler to measure these inch marks to verify that printout is correctly sized.

To make complete pattern, join the following pages, following the diagram for reference.

THE SECRET OF GETTING AHEAD  
IS GETTING *Started*



# Spring Has Sprung

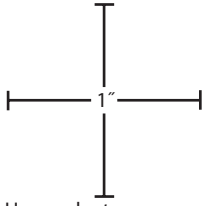

Use a ruler to measure these inch marks to verify that printout is correctly sized.

To make complete pattern, join the following pages, following the diagram for reference.

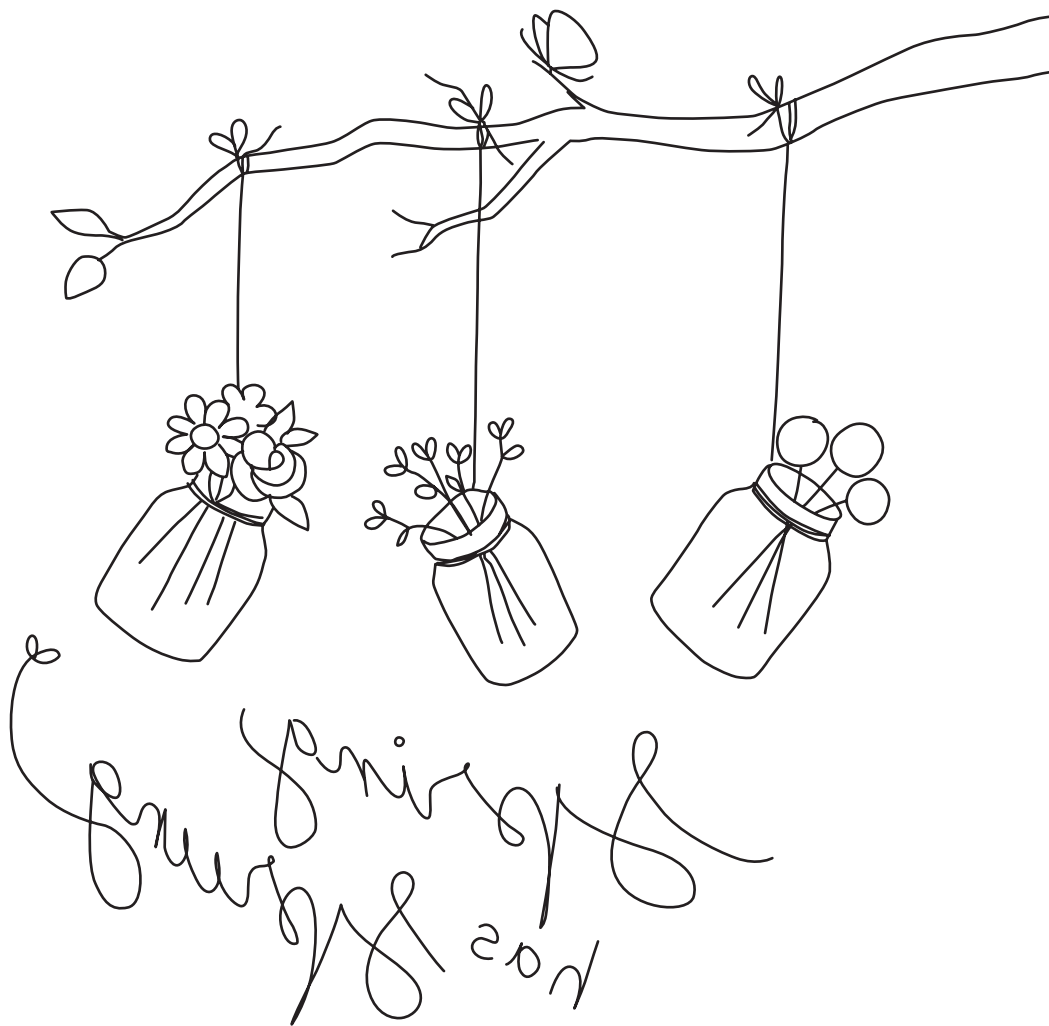

# Spring Has Sprung

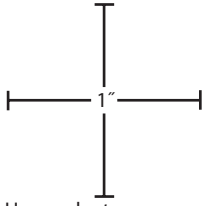

Use a ruler to measure these inch marks to verify that printout is correctly sized.

To make complete pattern, join the following pages, following the diagram for reference.



# Life with You Is Always a Picnic

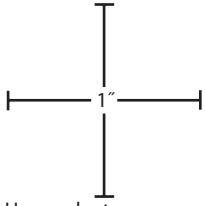

Use a ruler to measure these inch marks to verify that printout is correctly sized.

To make complete pattern, join the following pages, following the diagram for reference.

Life with you  
is always  
A PICNIC

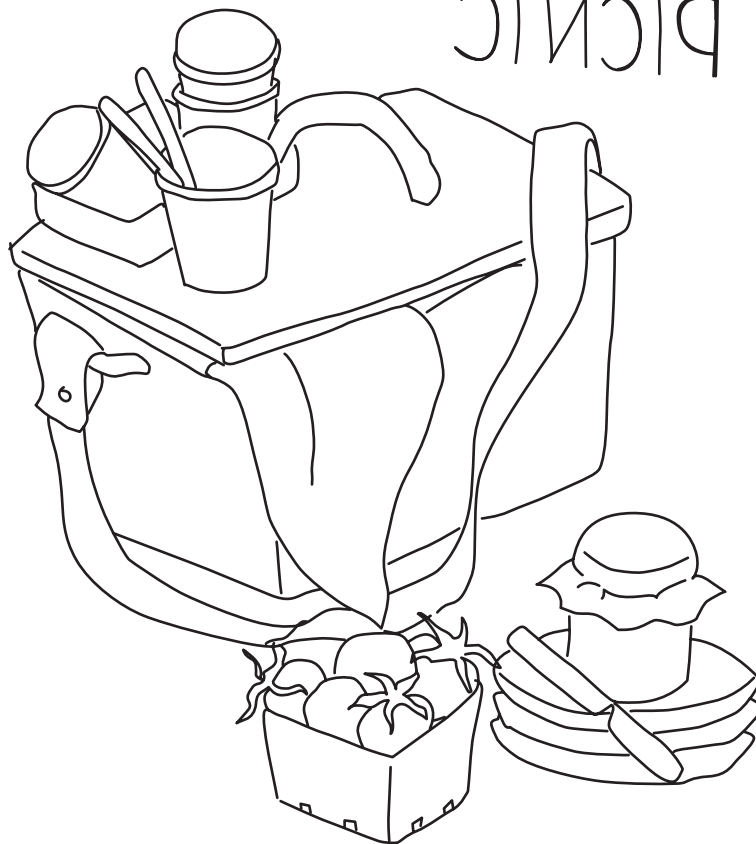

# Life with You Is Always a Picnic

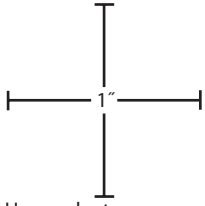

Use a ruler to measure these inch marks to verify that printout is correctly sized.

To make complete pattern, join the following pages, following the diagram for reference.

*life with you  
is always  
A PICNIC*

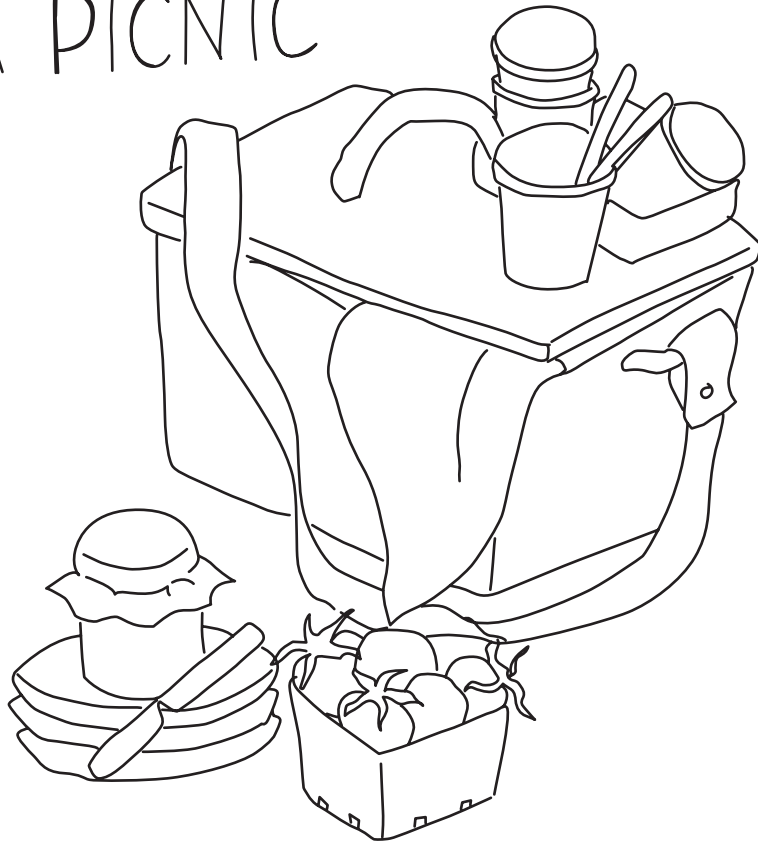



# Add a Whole Lot of Love to Everything You Create

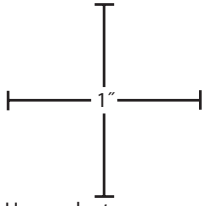

Use a ruler to measure these inch marks to verify that printout is correctly sized.

To make complete pattern, join the following pages, following the diagram for reference.

You Create  
LOVE to everything  
Add a whole lot of



## Add a Whole Lot of Love to Everything You Create

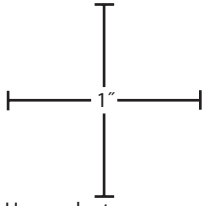

Use a ruler to measure these inch marks to verify that printout is correctly sized.

To make complete pattern, join the following pages, following the diagram for reference.

Add a whole lot of  
LOVE to everything  
You Create



# No Place like Home

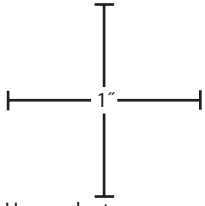

Use a ruler to measure these inch marks to verify that printout is correctly sized.

To make complete pattern, join the following pages, following the diagram for reference.



# No Place like Home

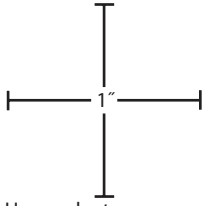

Use a ruler to measure these inch marks to verify that printout is correctly sized.

To make complete pattern, join the following pages, following the diagram for reference.



NO PLACE  
*like home*

# Begin Each Day with a Greatful Heart

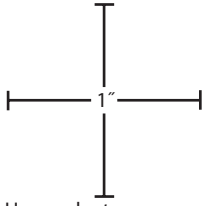

Use a ruler to measure these inch marks to verify that printout is correctly sized.

To make complete pattern, join the following pages, following the diagram for reference.

Begin each day  
with a grateful  
heart



## Begin Each Day with a Greatful Heart

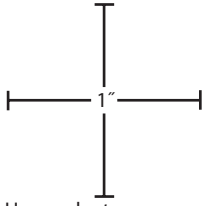

Use a ruler to measure these inch marks to verify that printout is correctly sized.

To make complete pattern, join the following pages, following the diagram for reference.

*Begin each day  
with a grateful  
heart*



# Hooray It's Today

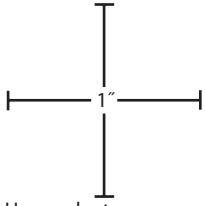

Use a ruler to measure these inch marks to verify that printout is correctly sized.

To make complete pattern, join the following pages, following the diagram for reference.

Hooray  
It's Today!



# Hooray It's Today

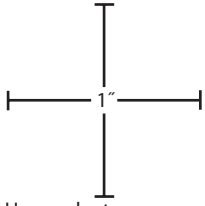

Use a ruler to measure these inch marks to verify that printout is correctly sized.

To make complete pattern, join the following pages, following the diagram for reference.

HOO RAY  
IT'S TODAY!





# Simple as That

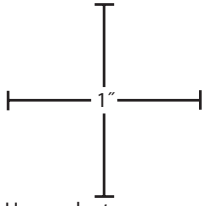

Use a ruler to measure these inch marks to verify that printout is correctly sized.

To make complete pattern, join the following pages, following the diagram for reference.

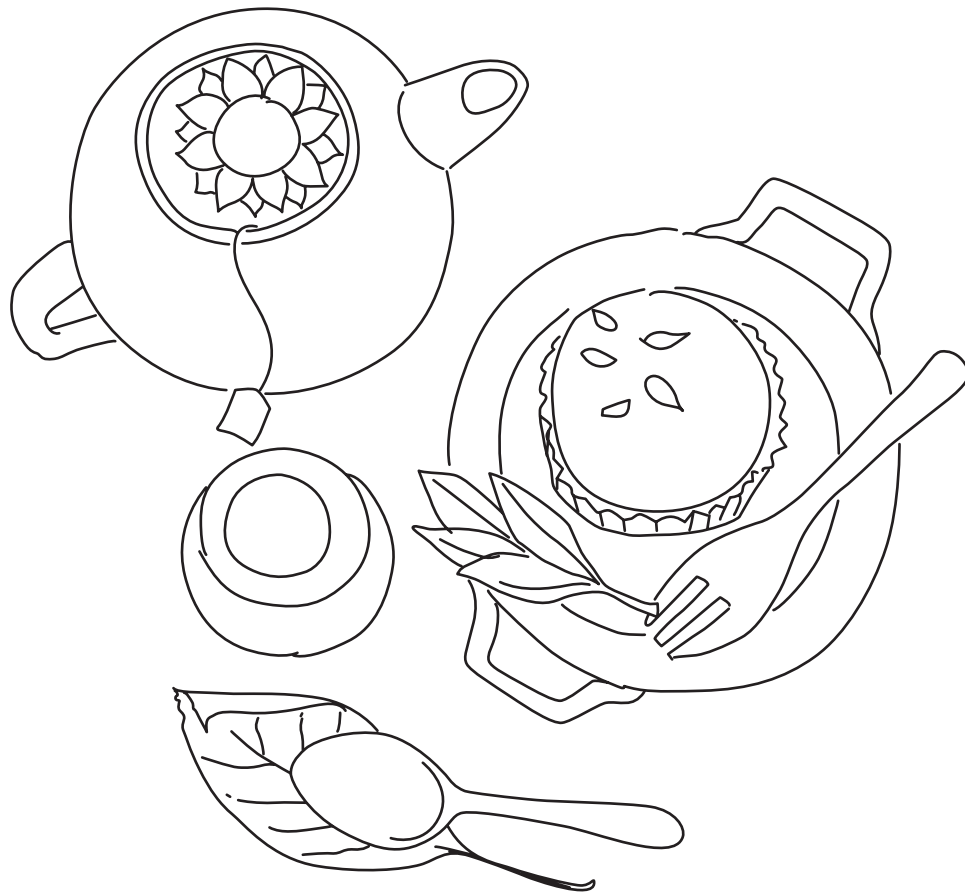

*as that* SIMPLE

# Simple as That

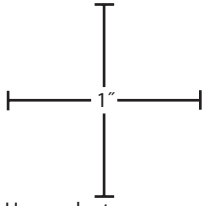

Use a ruler to measure these inch marks to verify that printout is correctly sized.

To make complete pattern, join the following pages, following the diagram for reference.

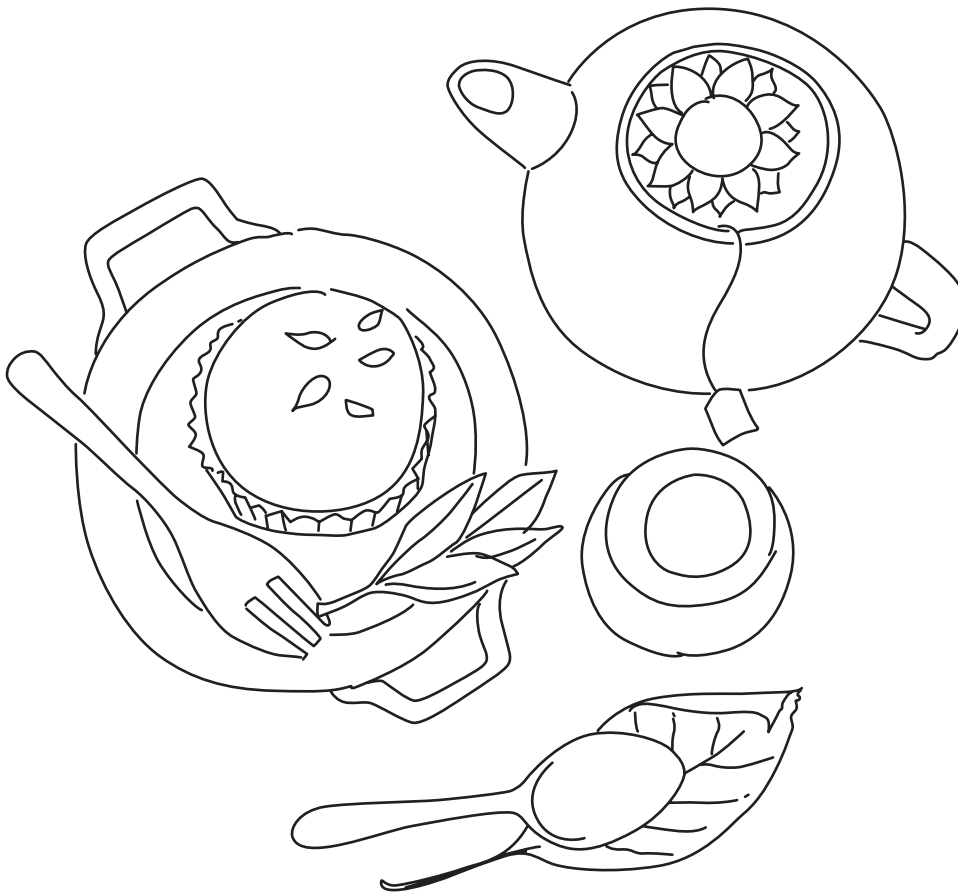

SIMPLE *as that*

# Little Moments

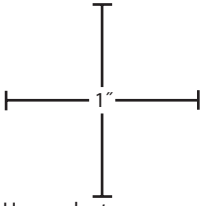

Use a ruler to measure these inch marks to verify that printout is correctly sized.

To make complete pattern, join the following pages, following the diagram for reference.



little moments

# Little Moments

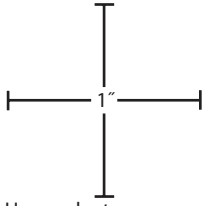

Use a ruler to measure these inch marks to verify that printout is correctly sized.

To make complete pattern, join the following pages, following the diagram for reference.



little moments

# Find Your Voice

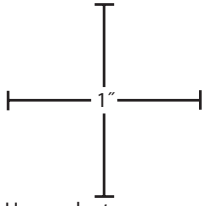

Use a ruler to measure these inch marks to verify that printout is correctly sized.

To make complete pattern, join the following pages, following the diagram for reference.

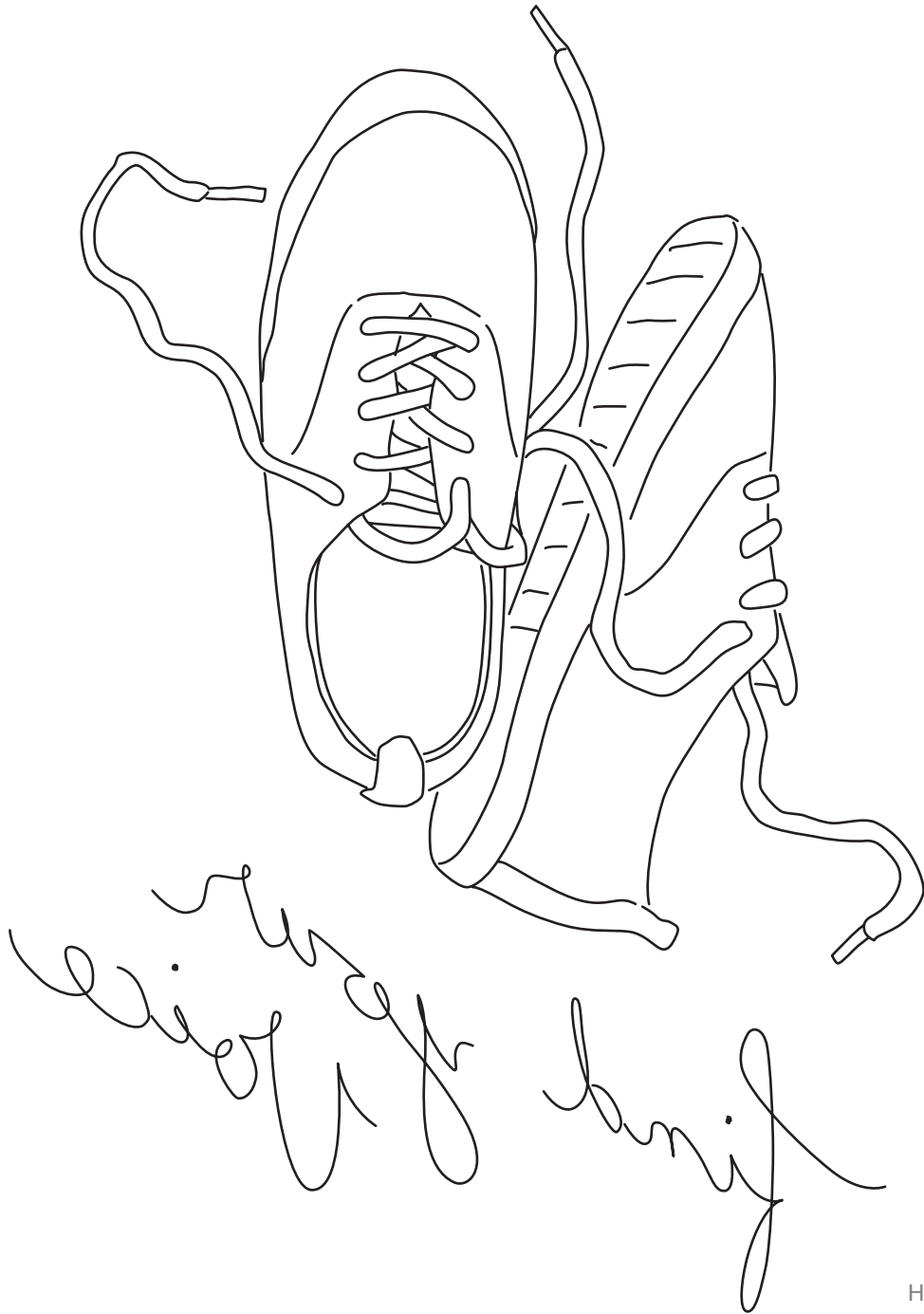

## Find Your Voice

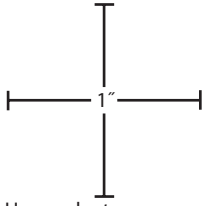

Use a ruler to measure these inch marks to verify that printout is correctly sized.

To make complete pattern, join the following pages, following the diagram for reference.

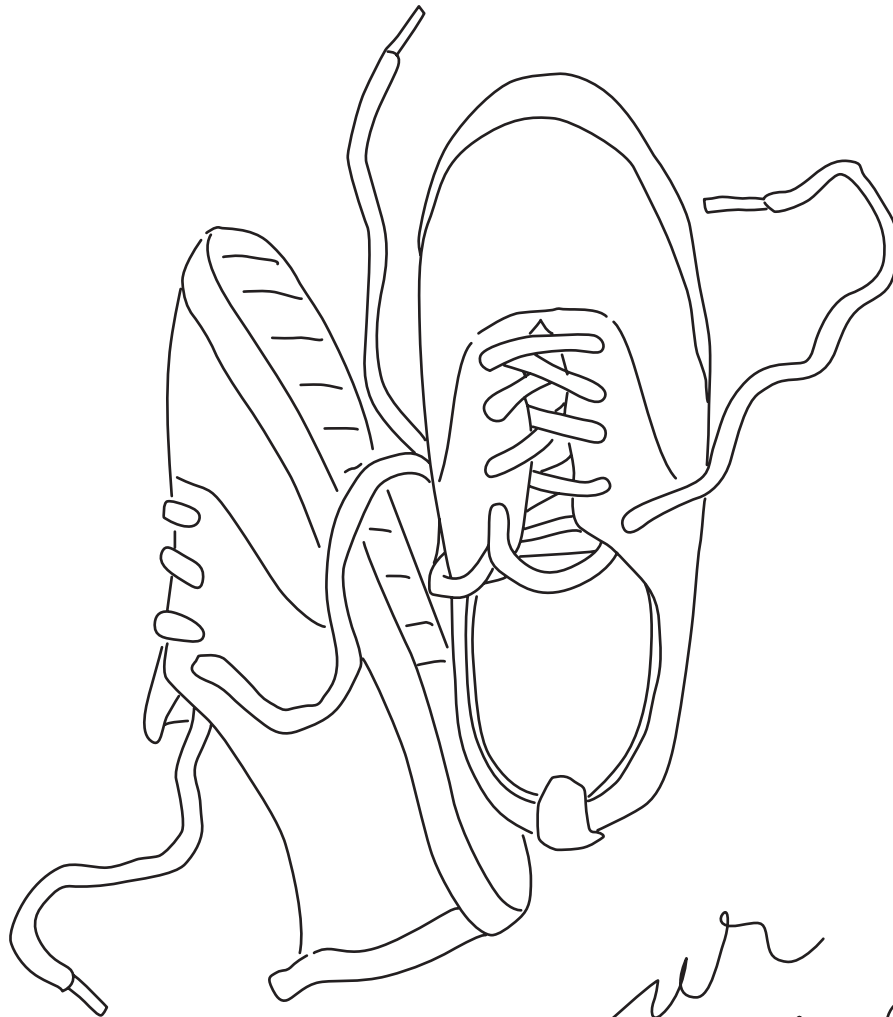

*find your voice*

# Find Your Own Path

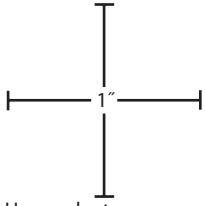

Use a ruler to measure these inch marks to verify that printout is correctly sized.

To make complete pattern, join the following pages, following the diagram for reference.

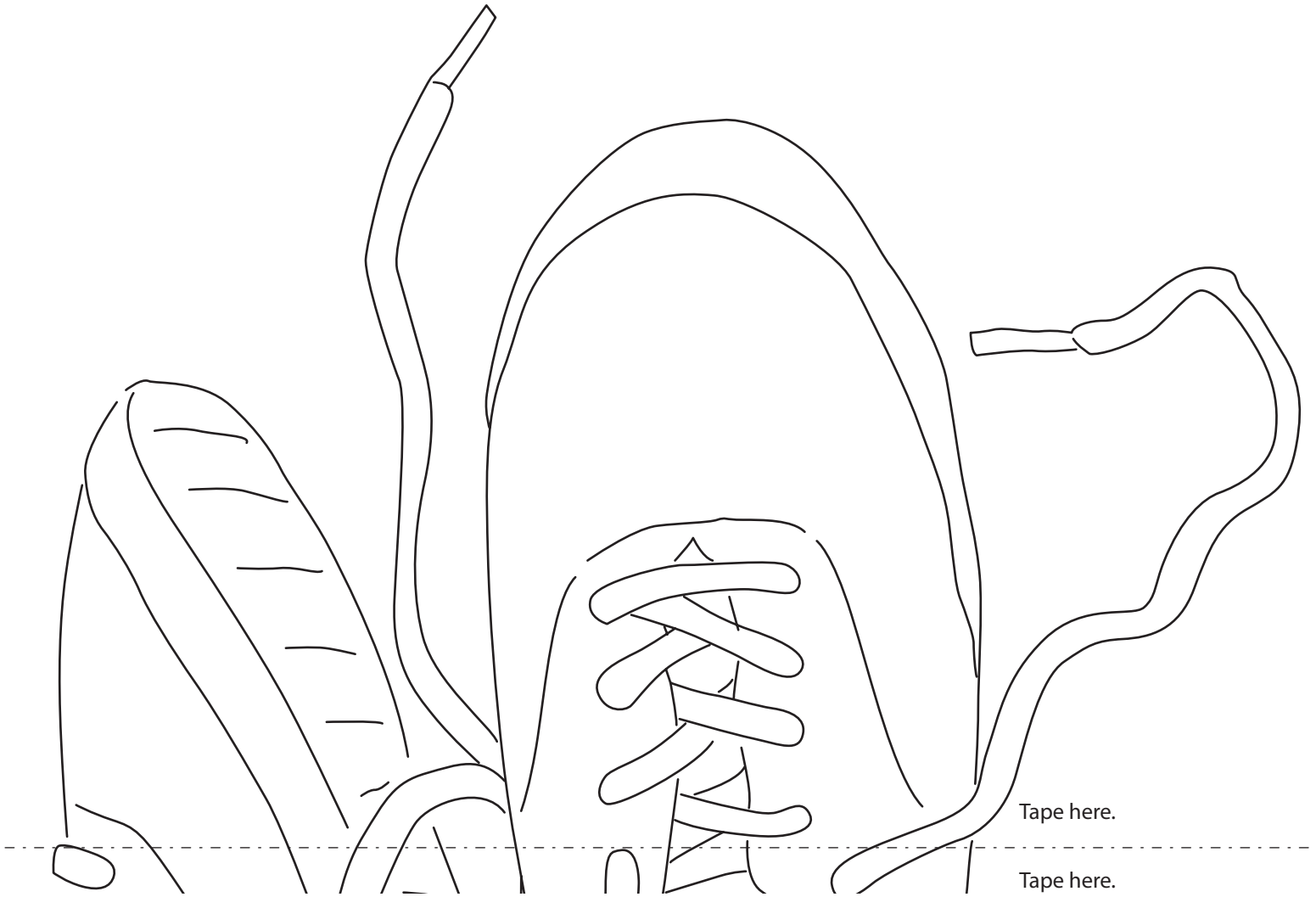
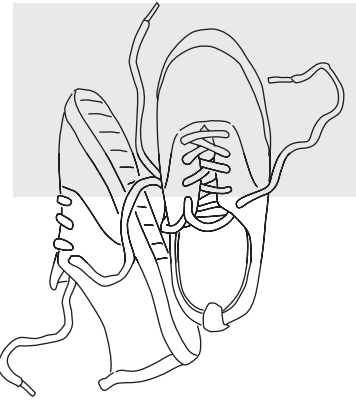

# Find Your Own Path

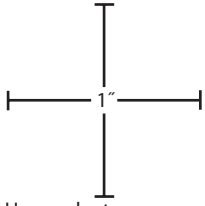

Use a ruler to measure these inch marks to verify that printout is correctly sized.

To make complete pattern, join the following pages, following the diagram for reference.

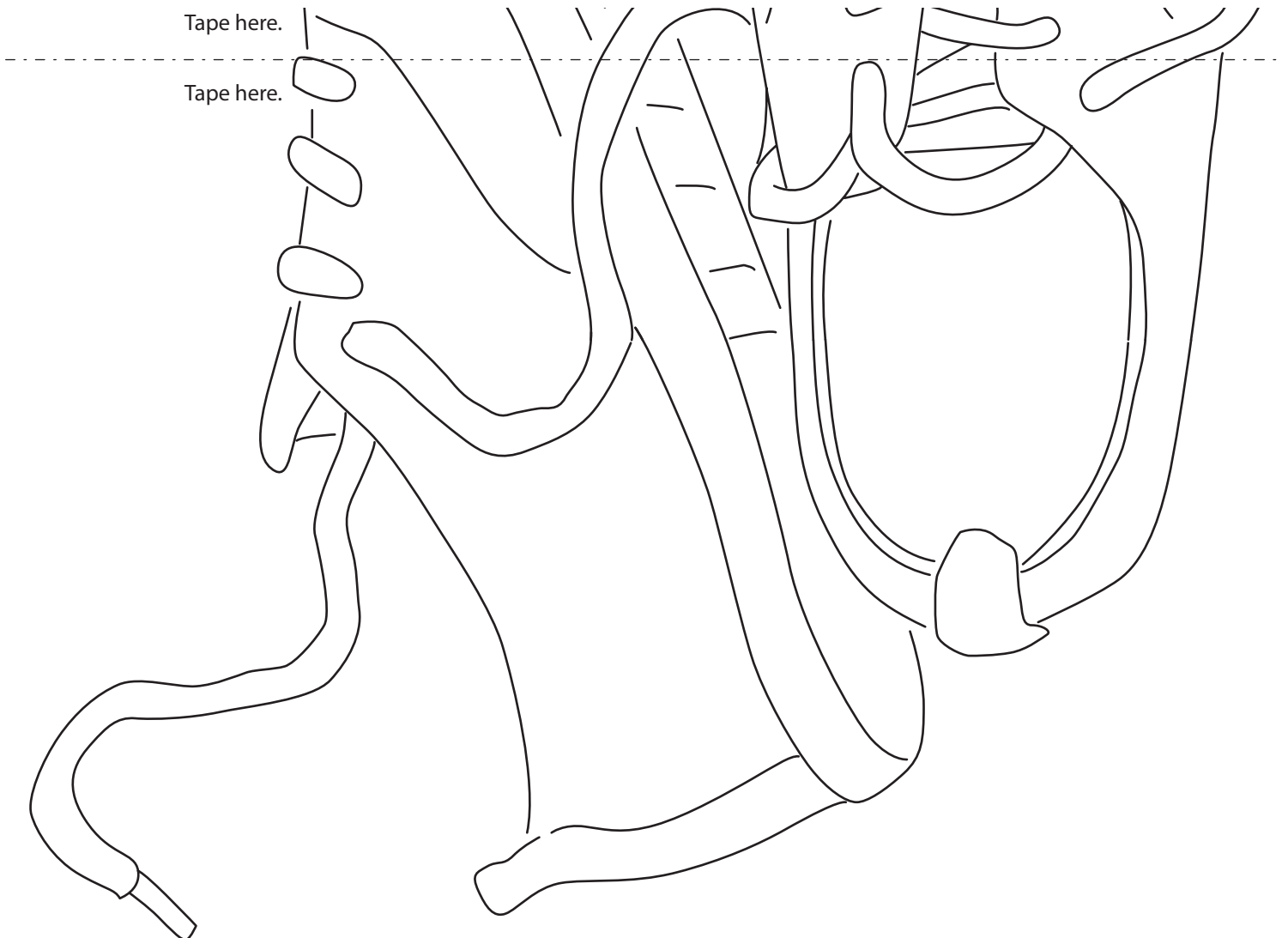
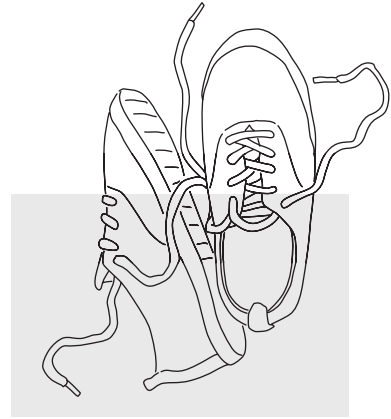

Humble Bundle



## Find Your Own Path

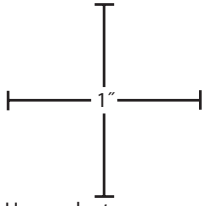

Use a ruler to measure these inch marks to verify that printout is correctly sized.

To make complete pattern, join the following pages, following the diagram for reference.

find your own path

find your own path

# Good Things Happen When You Go for It

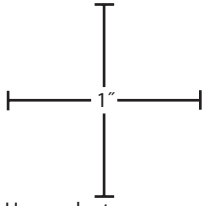

Use a ruler to measure these inch marks to verify that printout is correctly sized.

To make complete pattern, join the following pages, following the diagram for reference.

WHEN YOU GO FOR IT  
GOOD THINGS HAPPEN



# Good Things Happen When You Go for It

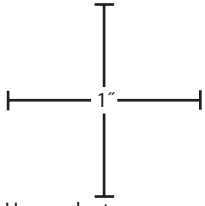

Use a ruler to measure these inch marks to verify that printout is correctly sized.

To make complete pattern, join the following pages, following the diagram for reference.

GOOD THINGS HAPPEN  
WHEN YOU GO FOR IT



# Thank You

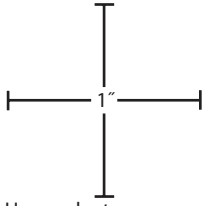

Use a ruler to measure these inch marks to verify that printout is correctly sized.

To make complete pattern, join the following pages, following the diagram for reference.

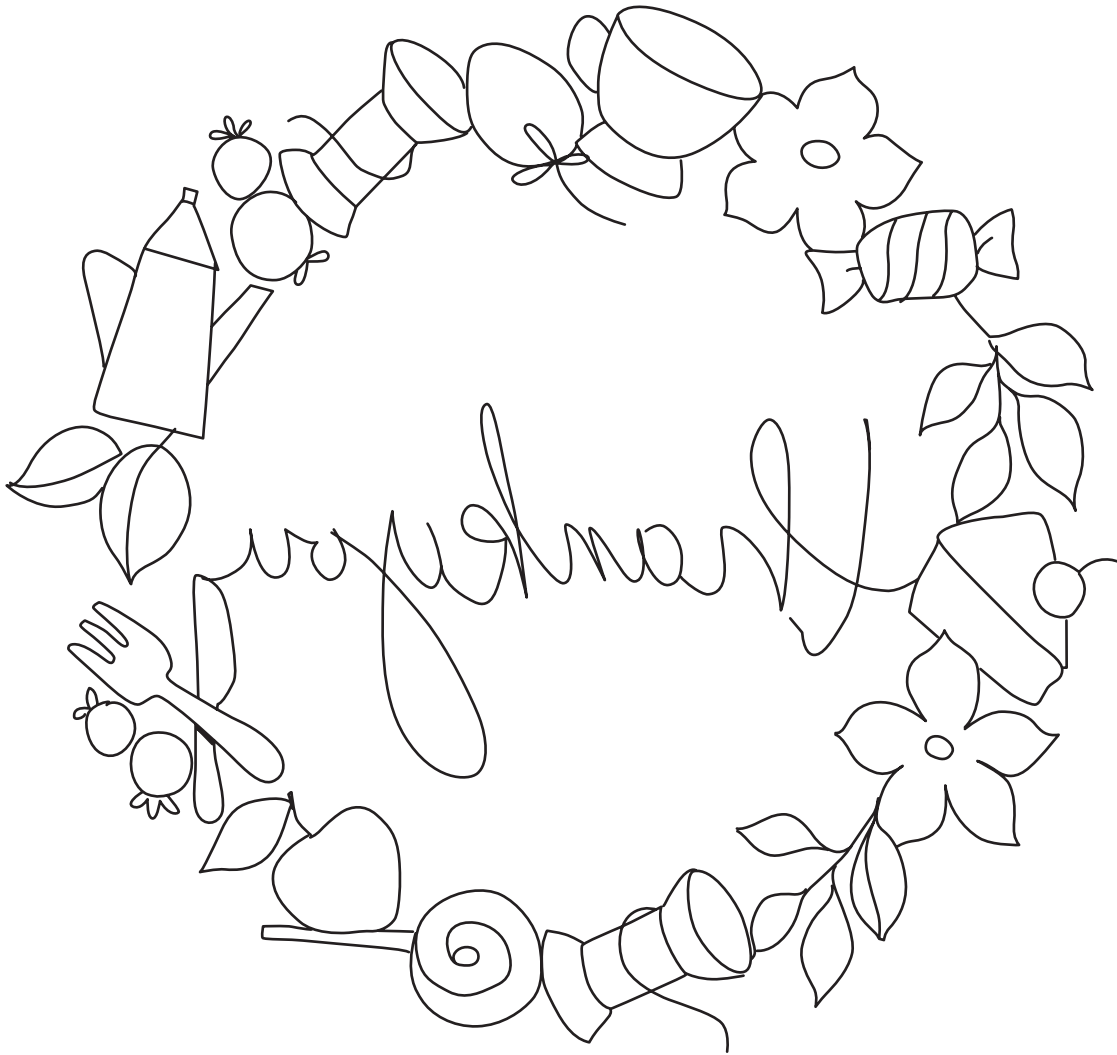



# Away

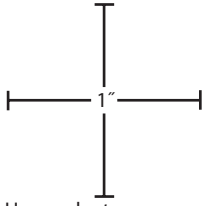

Use a ruler to measure these inch marks to verify that printout is correctly sized.

To make complete pattern, join the following pages, following the diagram for reference.

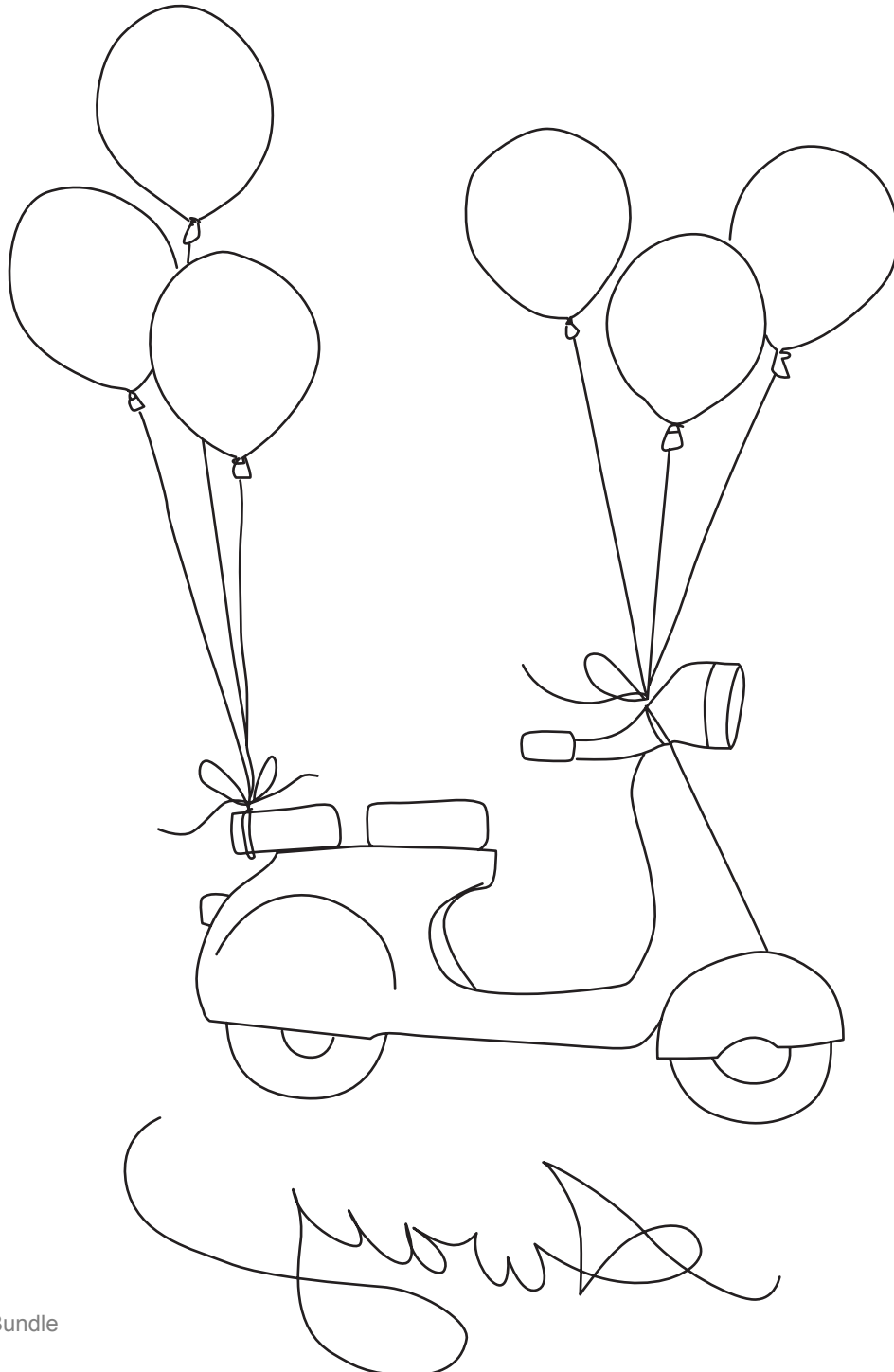

# Away

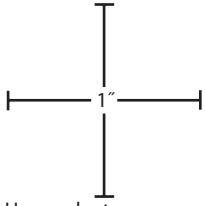

Use a ruler to measure these inch marks to verify that printout is correctly sized.

To make complete pattern, join the following pages, following the diagram for reference.

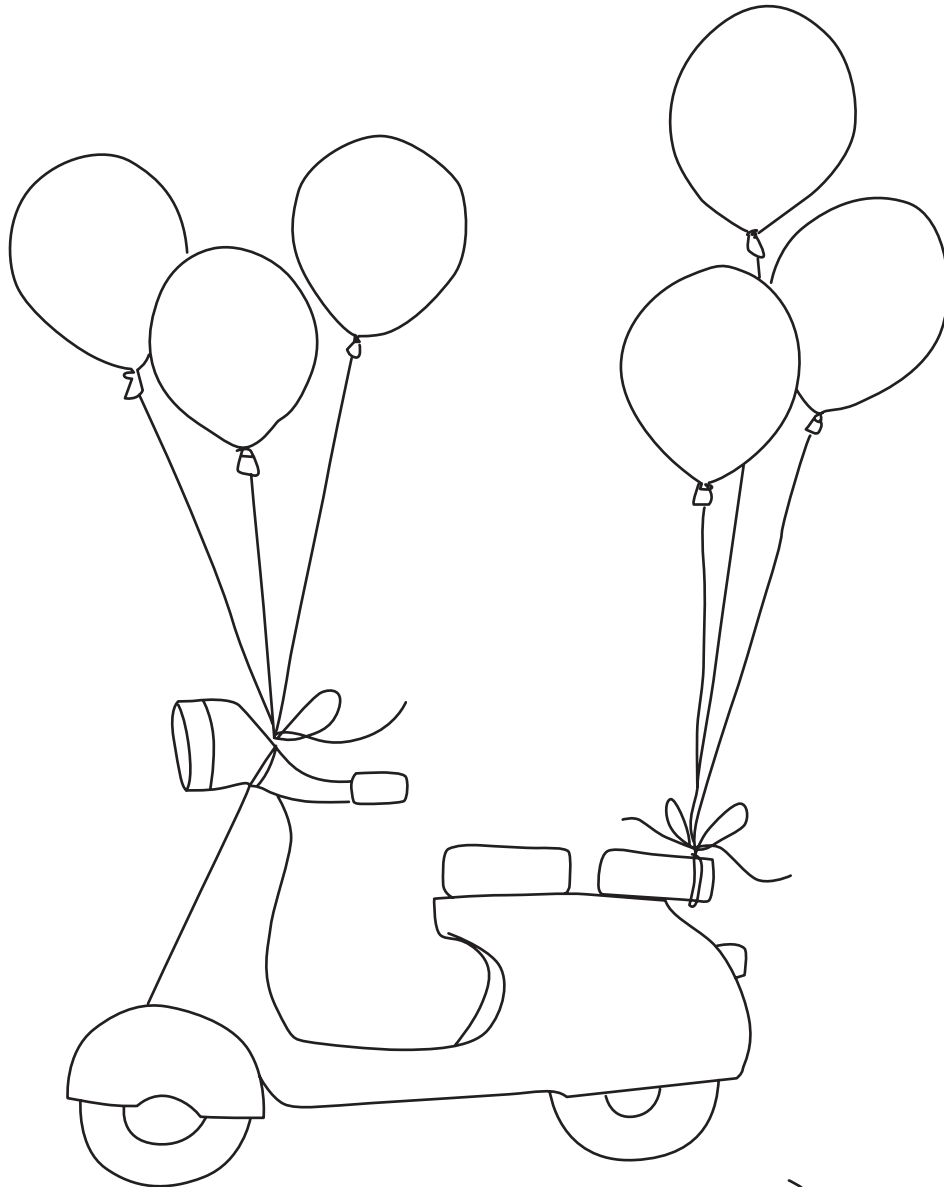

*Away*

# A Girl with Bunny 1

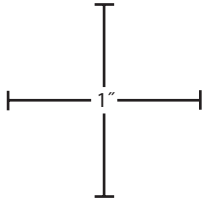

Use a ruler to measure these inch marks to verify that printout is correctly sized.

To make complete pattern, join the following pages, following the diagram for reference.





# A Girl with Bunny 1

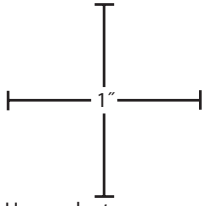

Use a ruler to measure these inch marks to verify that printout is correctly sized.

To make complete pattern, join the following pages, following the diagram for reference.



## A Girl with Bunny 2

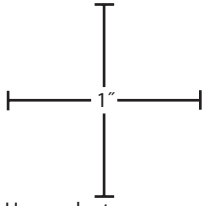

Use a ruler to measure these inch marks to verify that printout is correctly sized.

To make complete pattern, join the following pages, following the diagram for reference.



# A Girl with Bunny 2

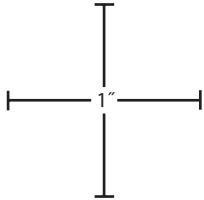

Use a ruler to measure these inch marks to verify that printout is correctly sized.

To make complete pattern, join the following pages, following the diagram for reference.



# Flower and Wreath Hanging

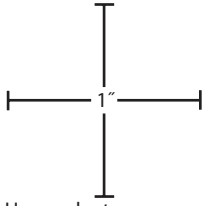

Use a ruler to measure these inch marks to verify that printout is correctly sized.

To make complete pattern, join the following pages, following the diagram for reference.

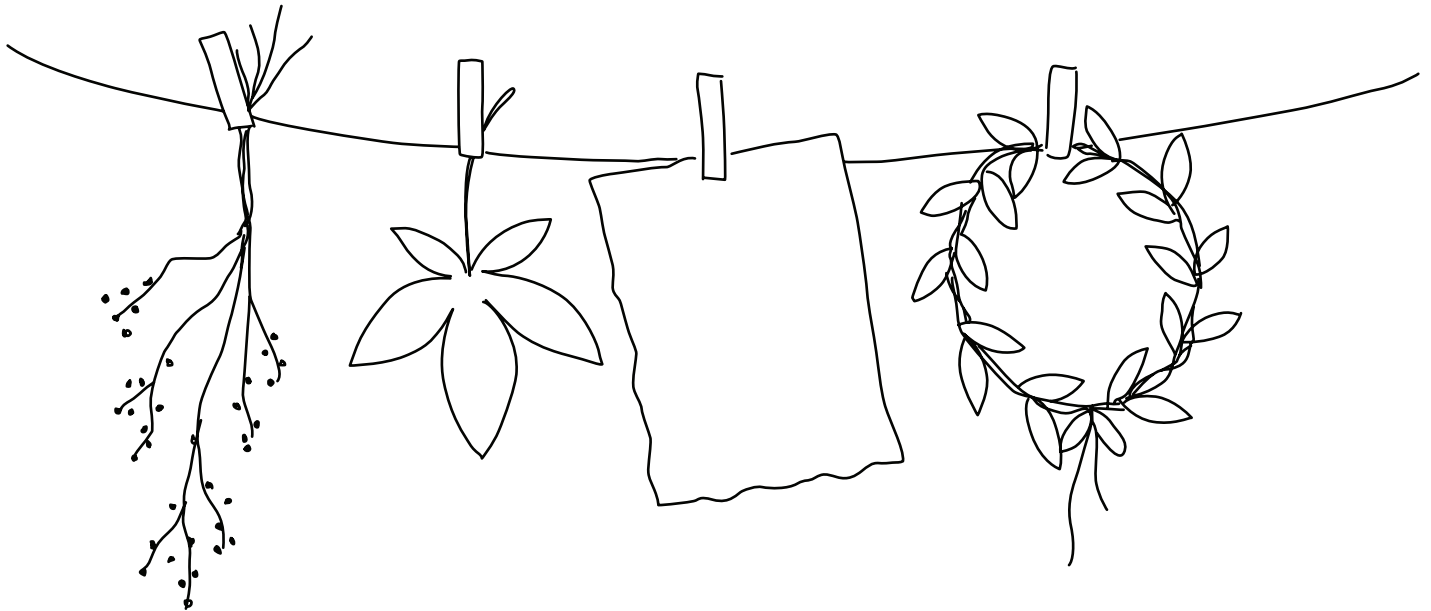

# Flower and Wreath Hanging

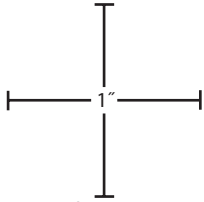

Use a ruler to measure these inch marks to verify that printout is correctly sized.

To make complete pattern, join the following pages, following the diagram for reference.

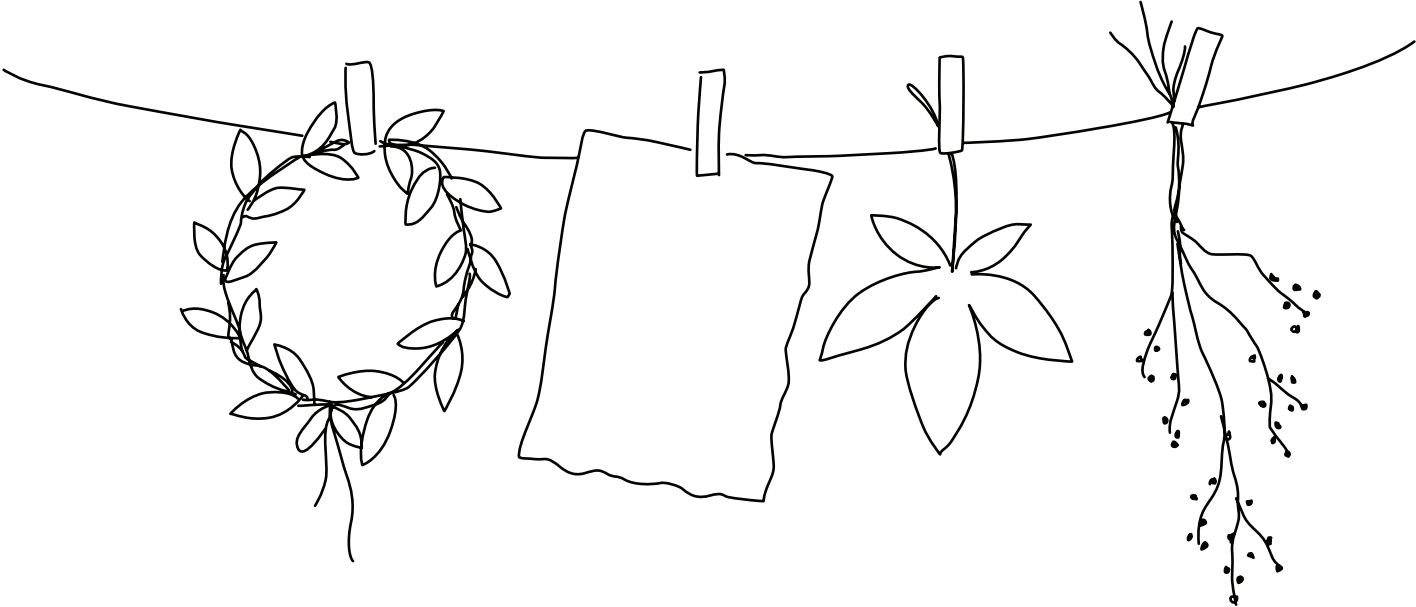

# You Are Loved

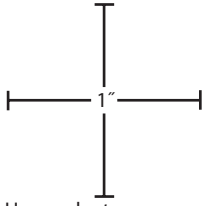

Use a ruler to measure these inch marks to verify that printout is correctly sized.

To make complete pattern, join the following pages, following the diagram for reference.

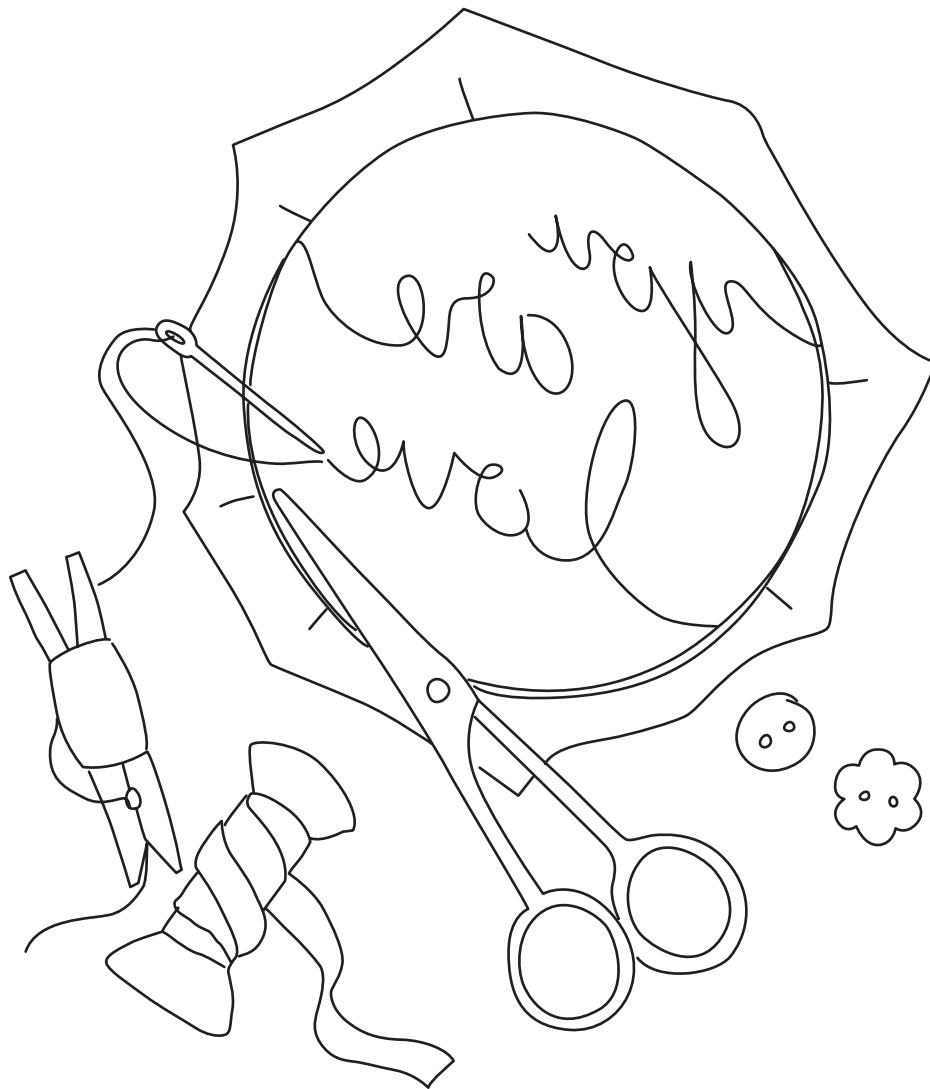

# You Are Loved

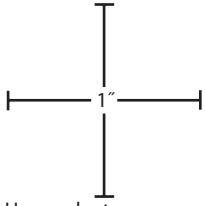

Use a ruler to measure these inch marks to verify that printout is correctly sized.

To make complete pattern, join the following pages, following the diagram for reference.

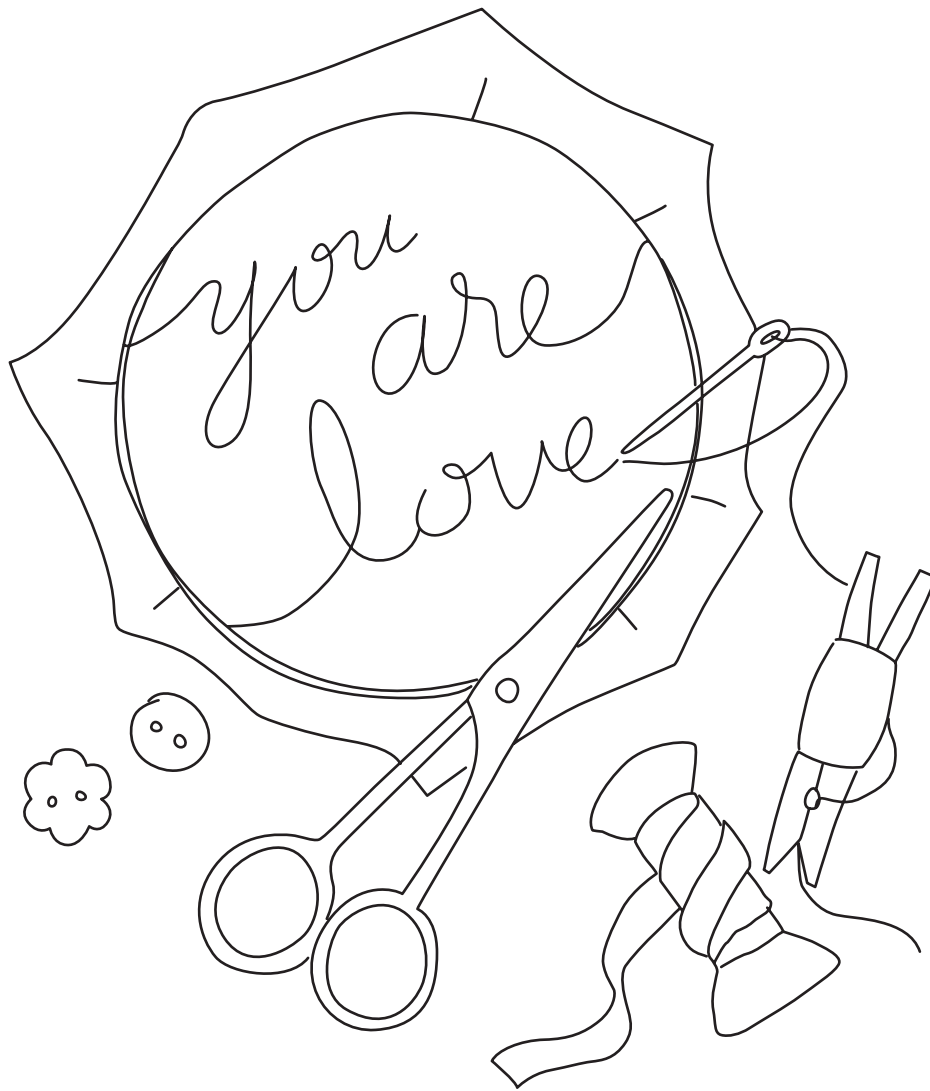

# House Hoops

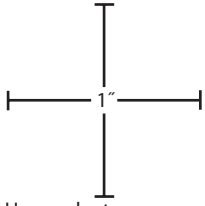

Use a ruler to measure these inch marks to verify that printout is correctly sized.

To make complete pattern, join the following pages, following the diagram for reference.

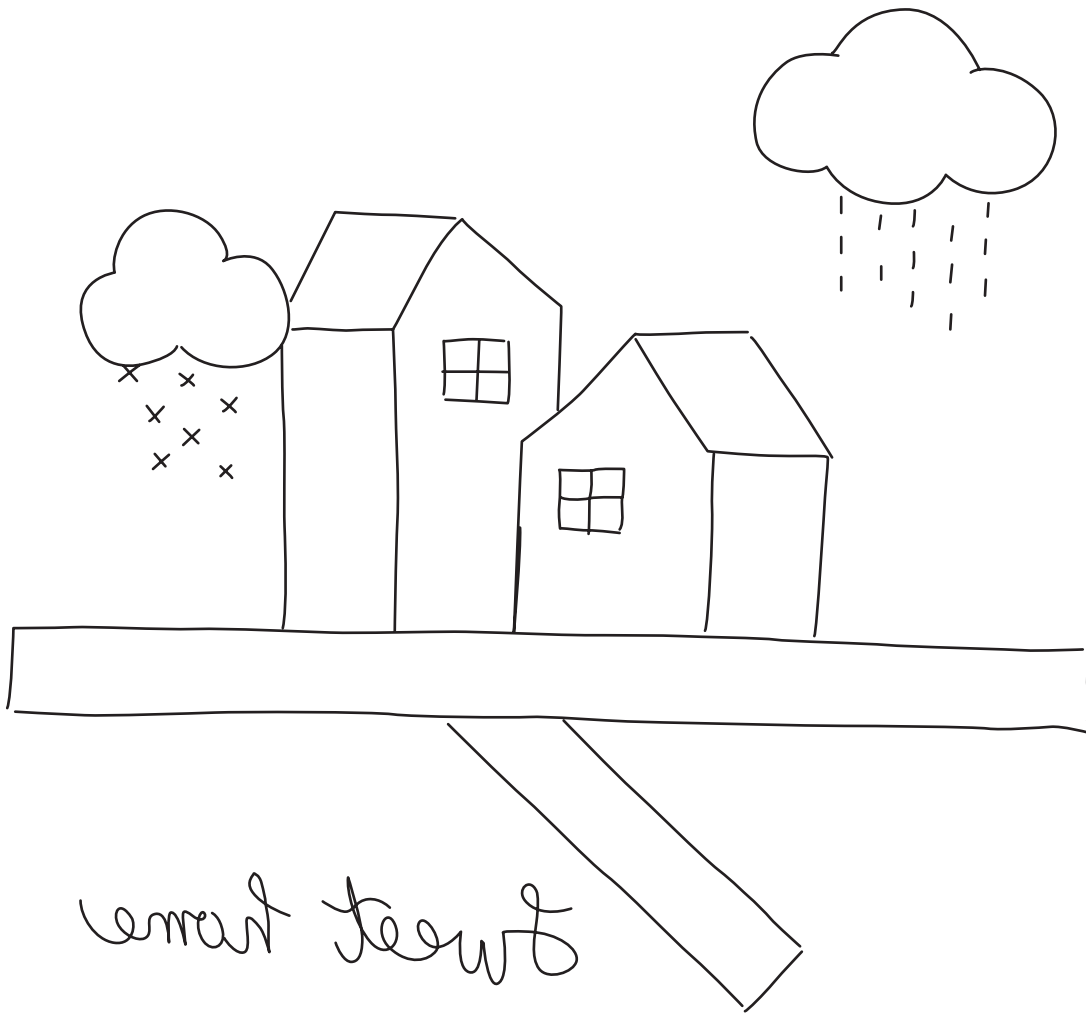



# House Hoops

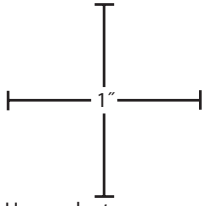

Use a ruler to measure these inch marks to verify that printout is correctly sized.

To make complete pattern, join the following pages, following the diagram for reference.



# House Hoops

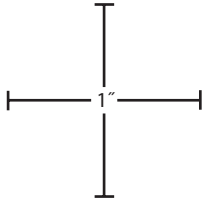

Use a ruler to measure these inch marks to verify that printout is correctly sized.

To make complete pattern, join the following pages, following the diagram for reference.

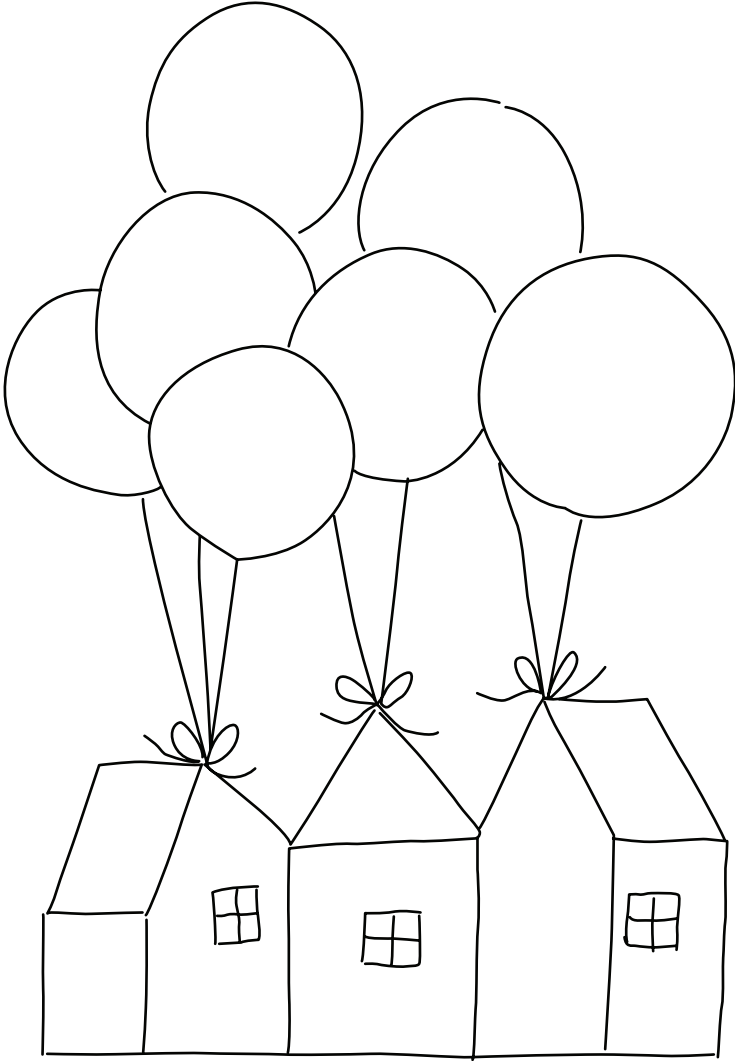

# House Hoops

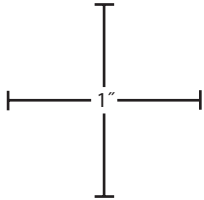

Use a ruler to measure these inch marks to verify that printout is correctly sized.

To make complete pattern, join the following pages, following the diagram for reference.

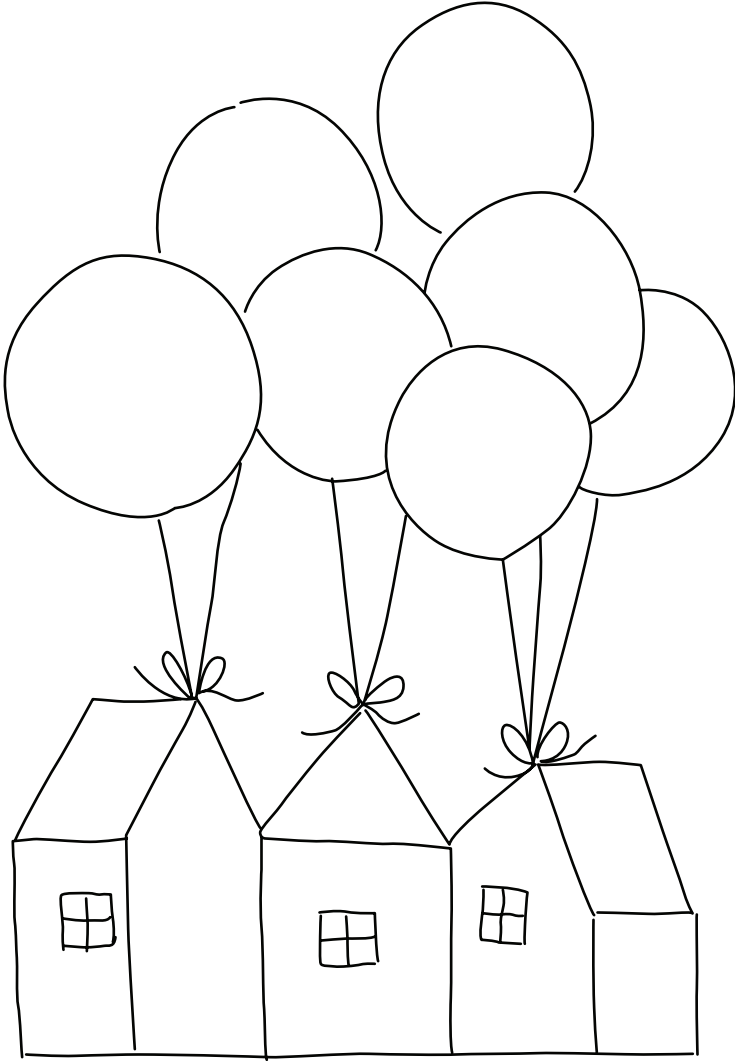

# House Hoops

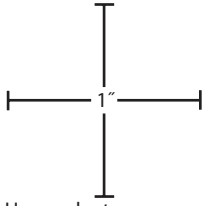

Use a ruler to measure these inch marks to verify that printout is correctly sized.

To make complete pattern, join the following pages, following the diagram for reference.



# House Hoops

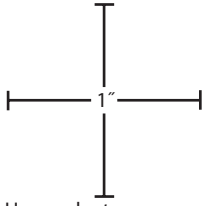

Use a ruler to measure these inch marks to verify that printout is correctly sized.

To make complete pattern, join the following pages, following the diagram for reference.



# My Kitchen

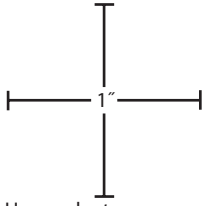

Use a ruler to measure these inch marks to verify that printout is correctly sized.

To make complete pattern, join the following pages, following the diagram for reference.

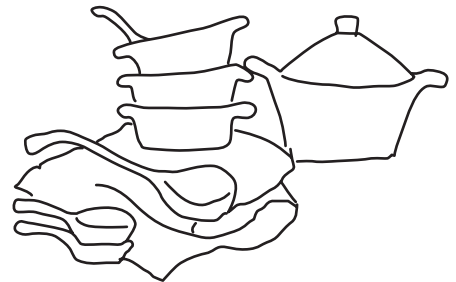
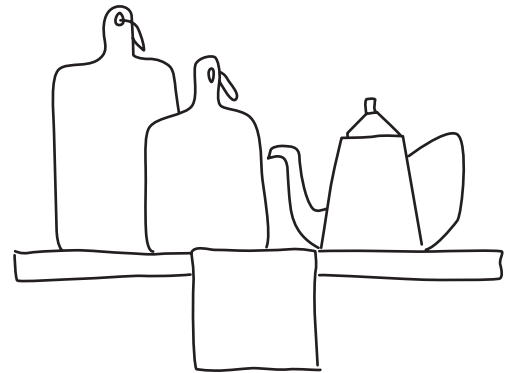
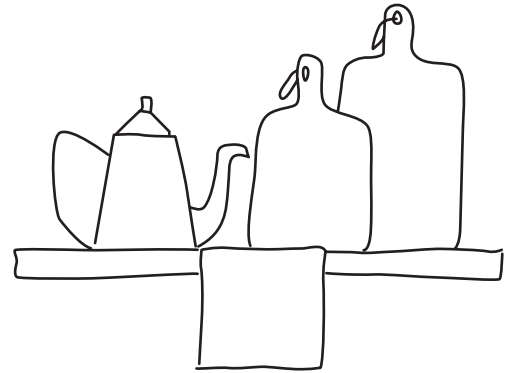

# My Kitchen

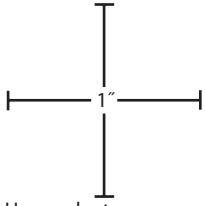

Use a ruler to measure these inch marks to verify that printout is correctly sized.

To make complete pattern, join the following pages, following the diagram for reference.

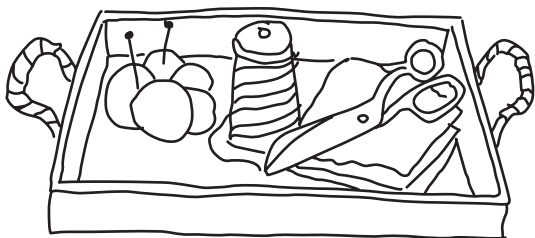
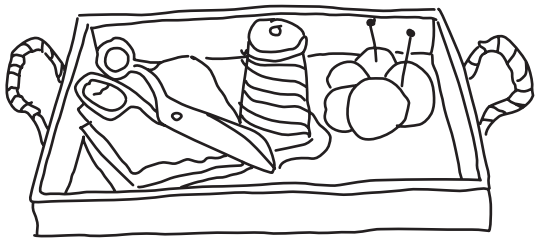
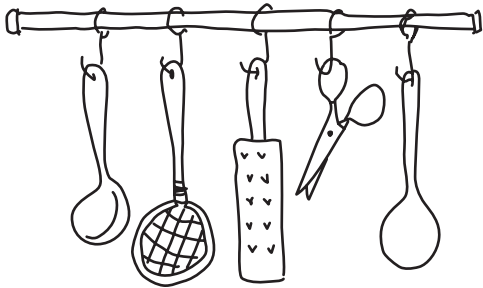
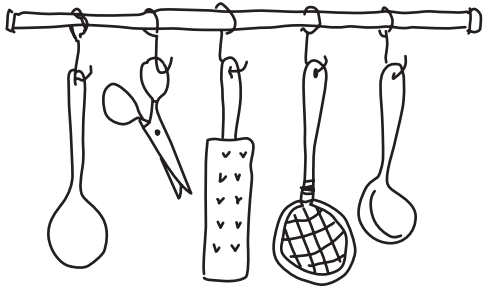

# Hoops for Home

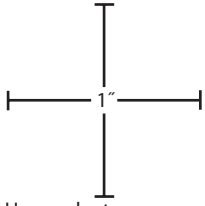

Use a ruler to measure these inch marks to verify that printout is correctly sized.

To make complete pattern, join the following pages, following the diagram for reference.

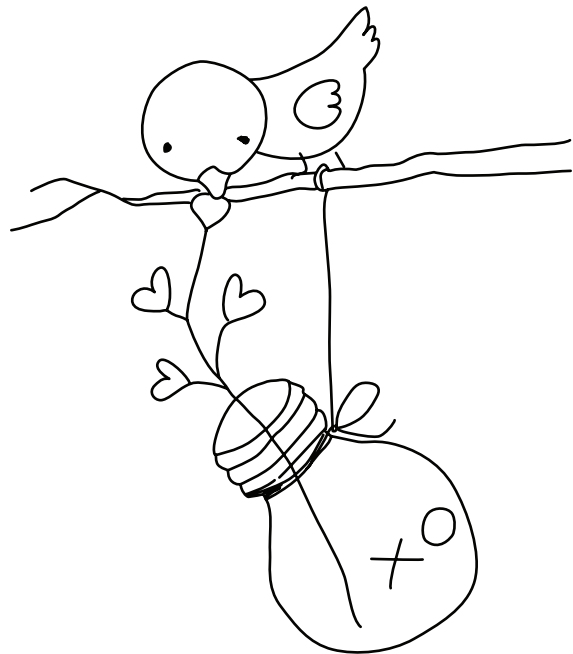
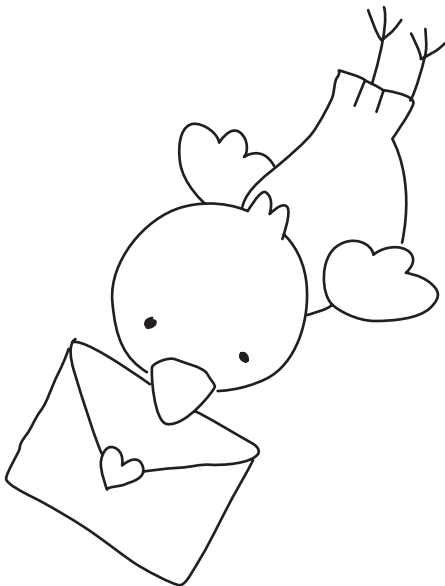
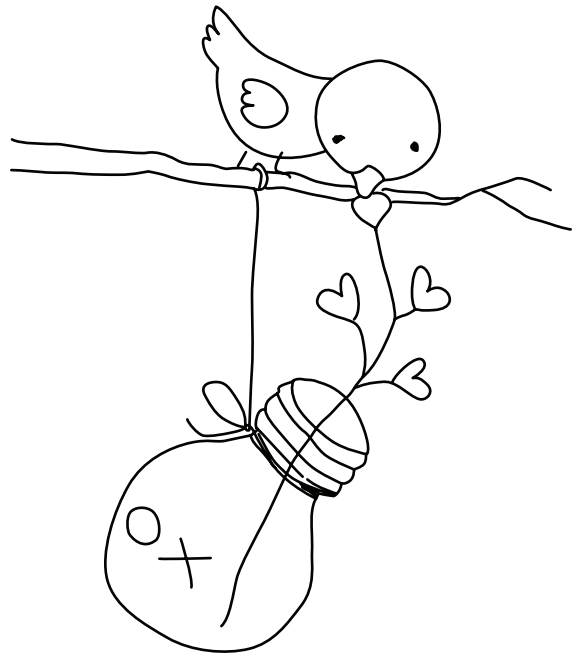
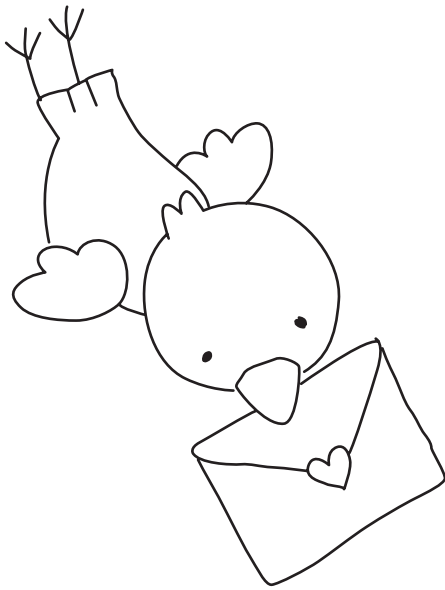



# Hoops for Home & Flower in a Bottle

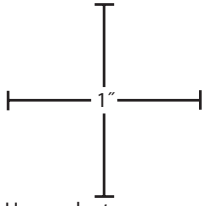

Use a ruler to measure these inch marks to verify that printout is correctly sized.

To make complete pattern, join the following pages, following the diagram for reference.

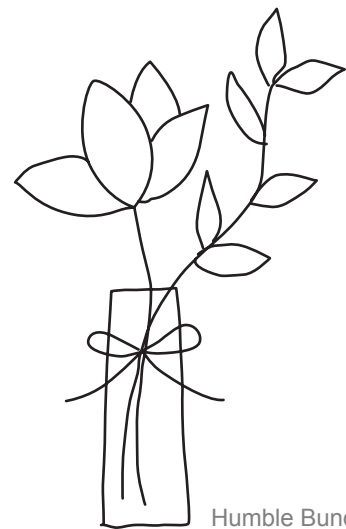
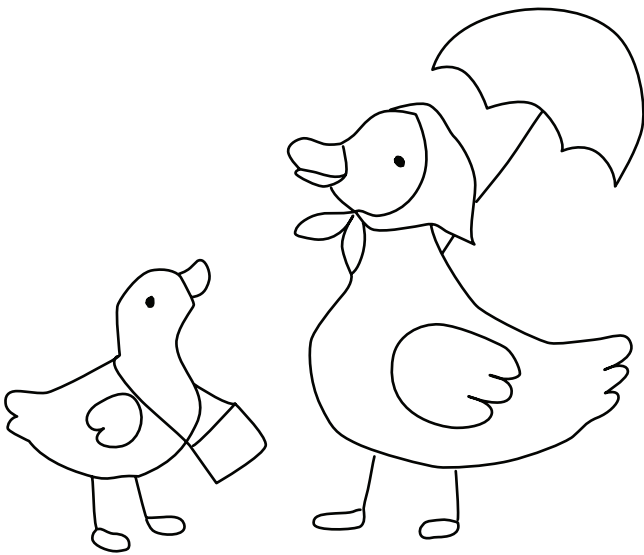
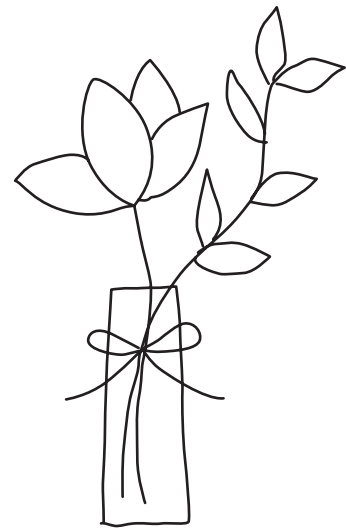
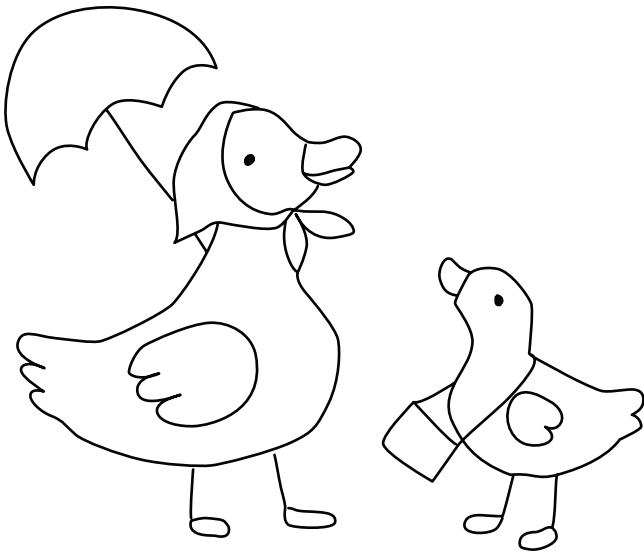

## Just Begin Wording & Rain Boots

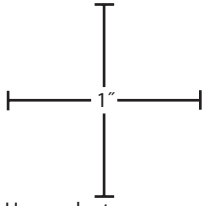

Use a ruler to measure these inch marks to verify that printout is correctly sized.

To make complete pattern, join the following pages, following the diagram for reference.

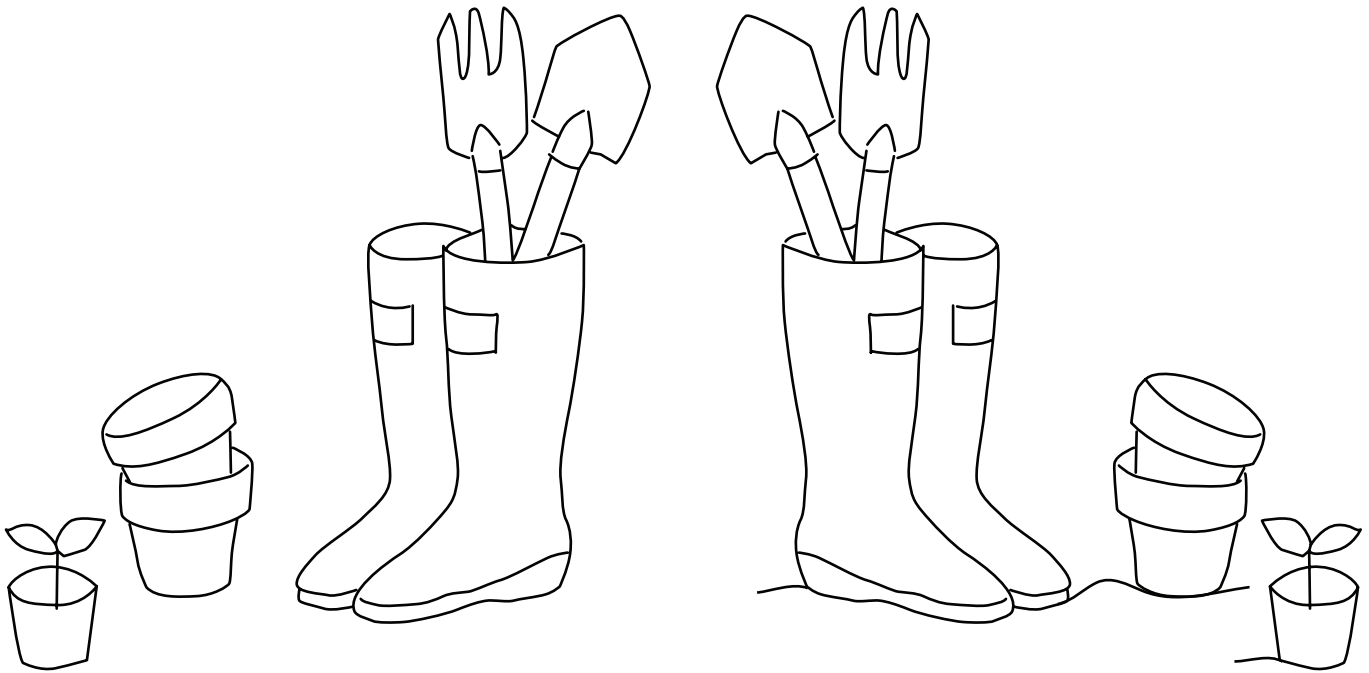

*nip of trow*

*just begin*

# We Have Each Other

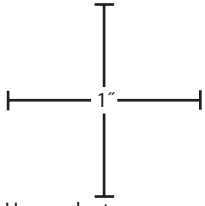

Use a ruler to measure these inch marks to verify that printout is correctly sized.

To make complete pattern, join the following pages, following the diagram for reference.

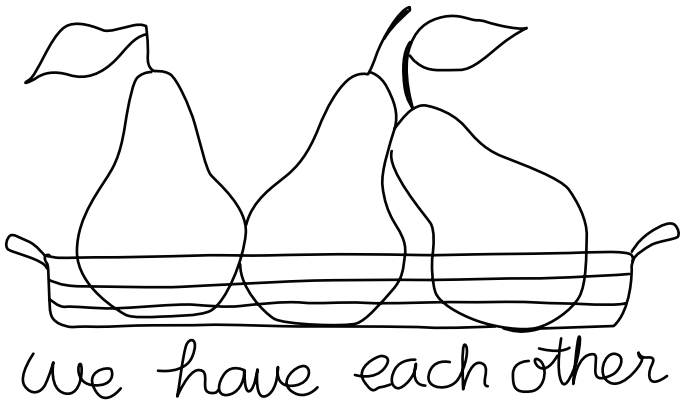
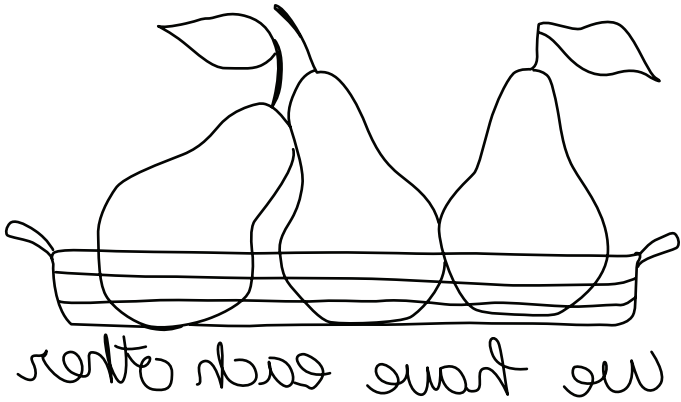

# Tulips

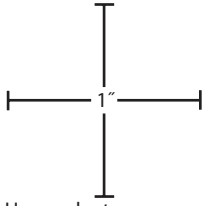

Use a ruler to measure these inch marks to verify that printout is correctly sized.

To make complete pattern, join the following pages, following the diagram for reference.

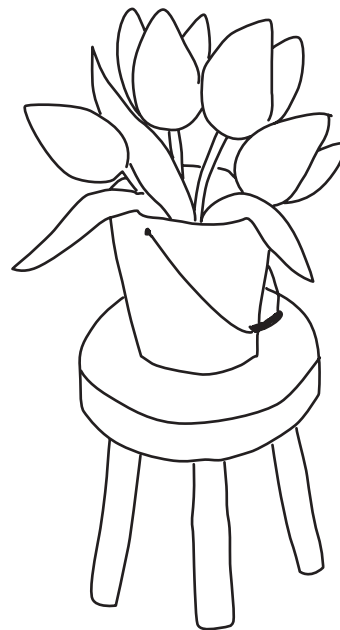
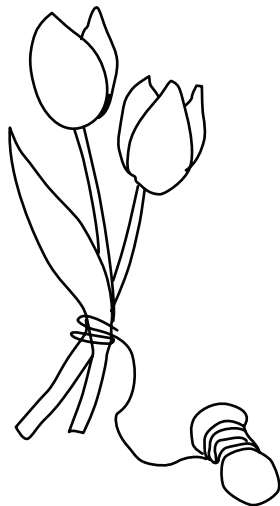
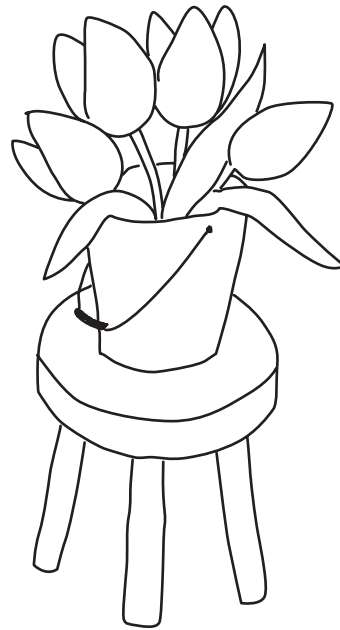
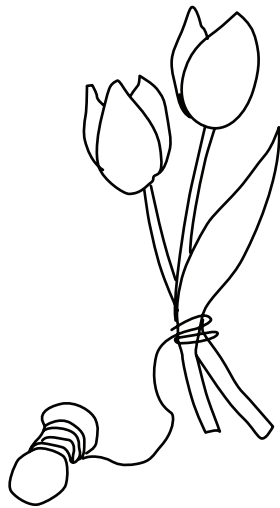

# Knitting Chick, Ribbons & Strawberry Bouquet

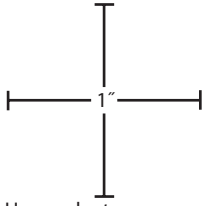

Use a ruler to measure these inch marks to verify that printout is correctly sized.

To make complete pattern, join the following pages, following the diagram for reference.

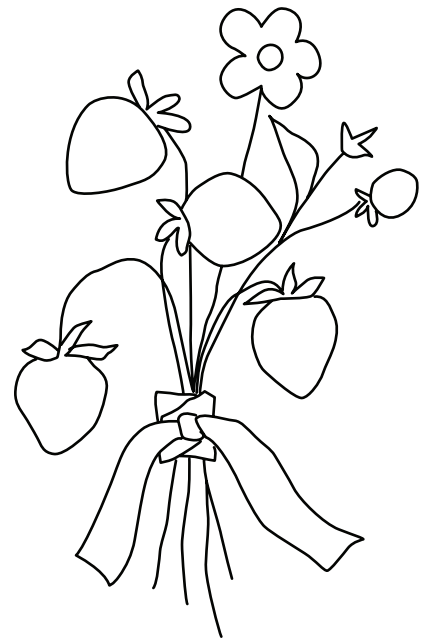
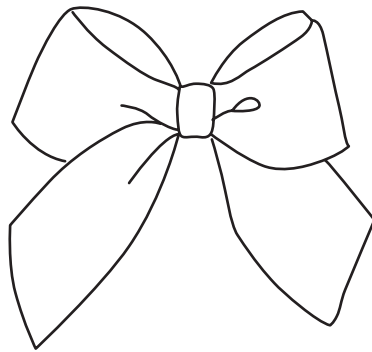
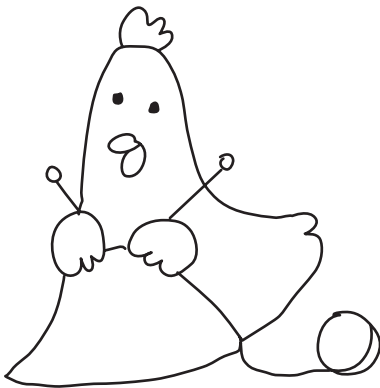
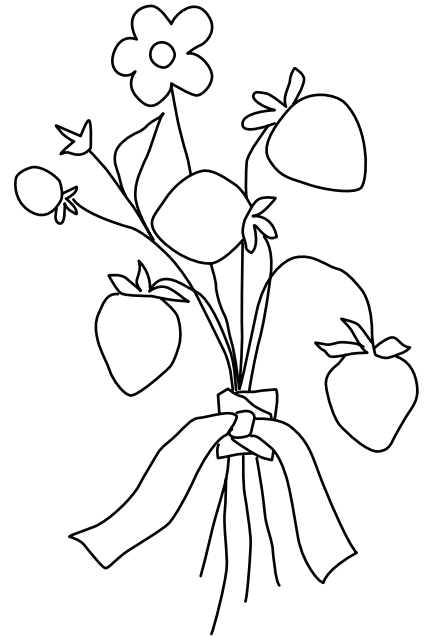

# More from My Kitchen

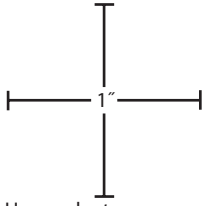

Use a ruler to measure these inch marks to verify that printout is correctly sized.

To make complete pattern, join the following pages, following the diagram for reference.

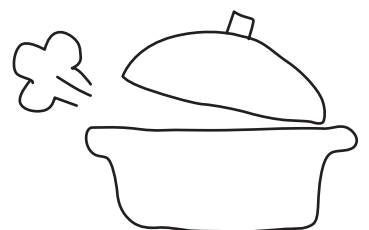
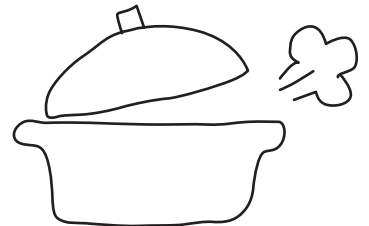
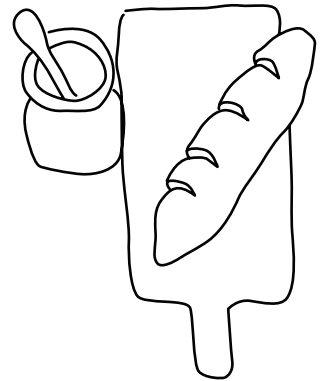
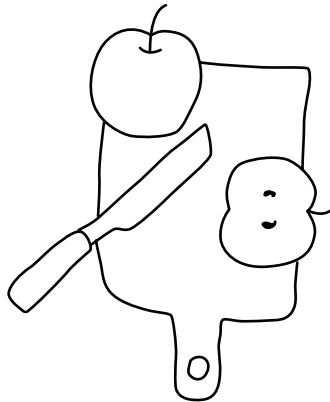
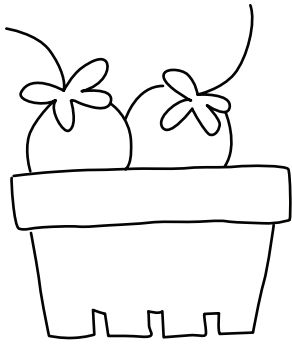
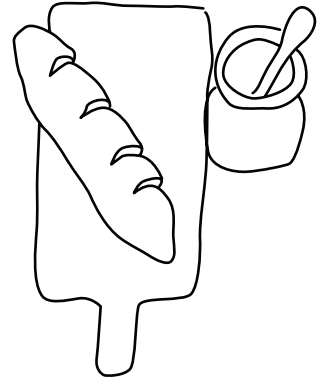
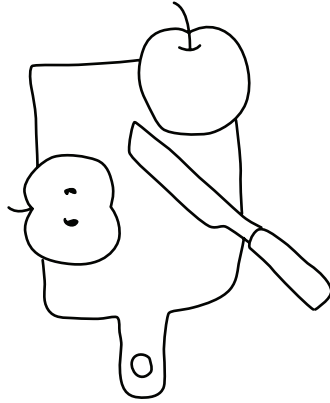
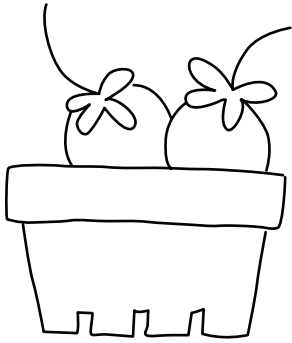

# Hoops for Home

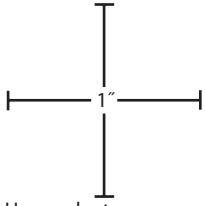

Use a ruler to measure these inch marks to verify that printout is correctly sized.

To make complete pattern, join the following pages, following the diagram for reference.

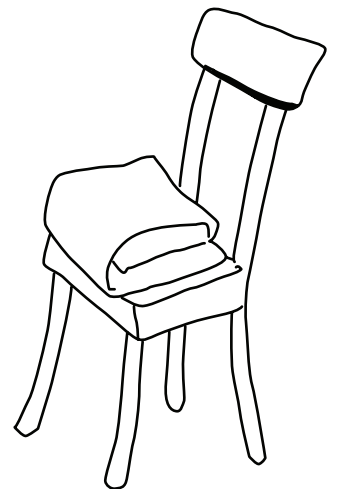
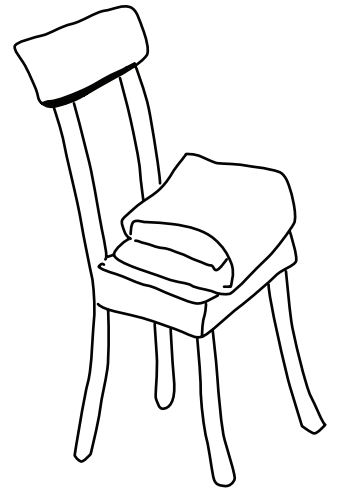

# Christmas Wishes

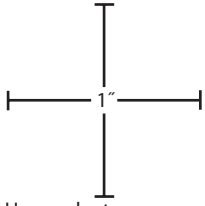

Use a ruler to measure these inch marks to verify that printout is correctly sized.

To make complete pattern, join the following pages, following the diagram for reference.

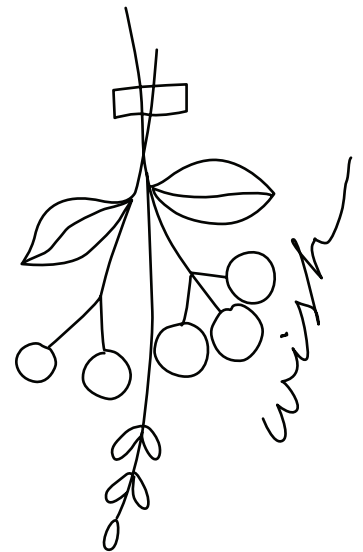
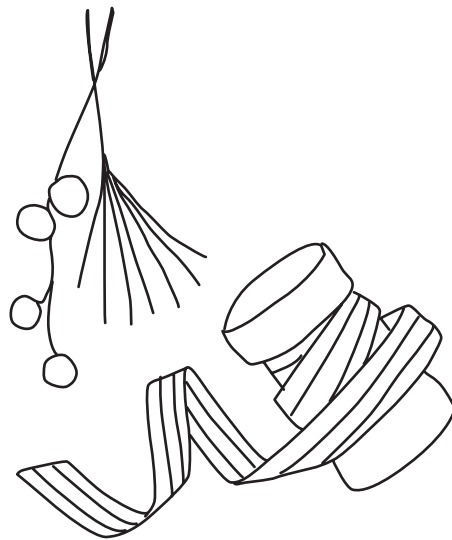
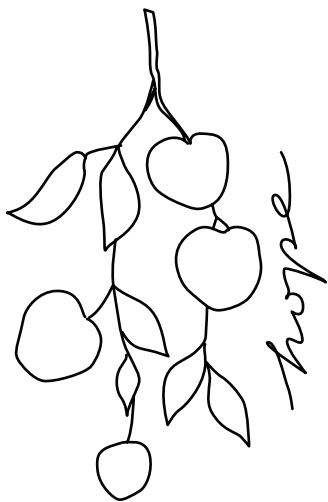
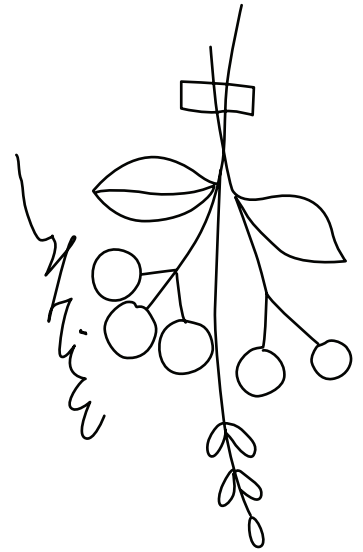
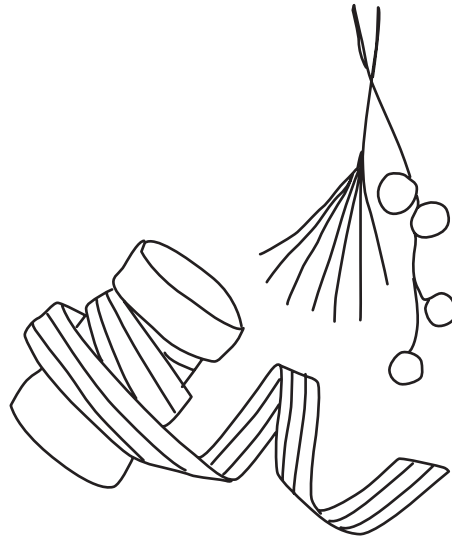
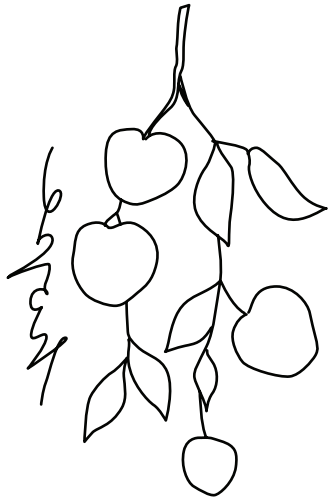

Humble Bundle



# Flower Bouquet & Scissors and Spool

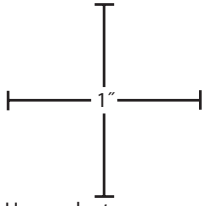

Use a ruler to measure these inch marks to verify that printout is correctly sized.

To make complete pattern, join the following pages, following the diagram for reference.

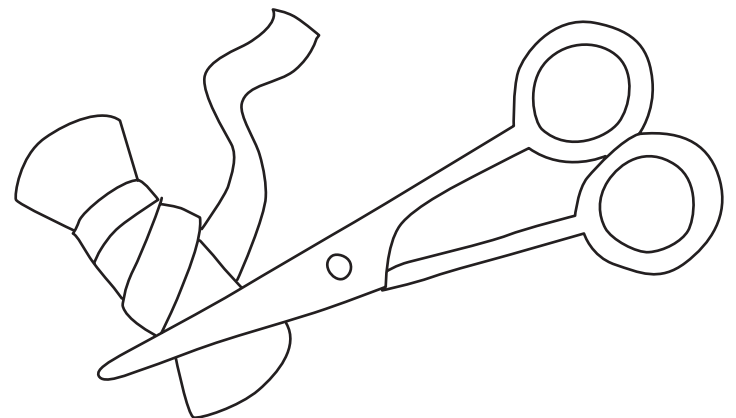
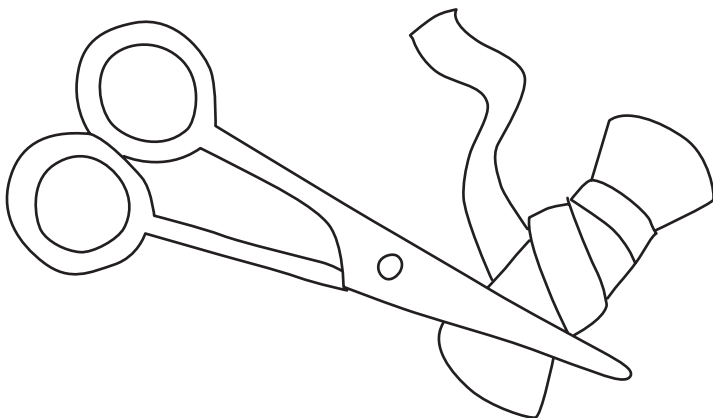
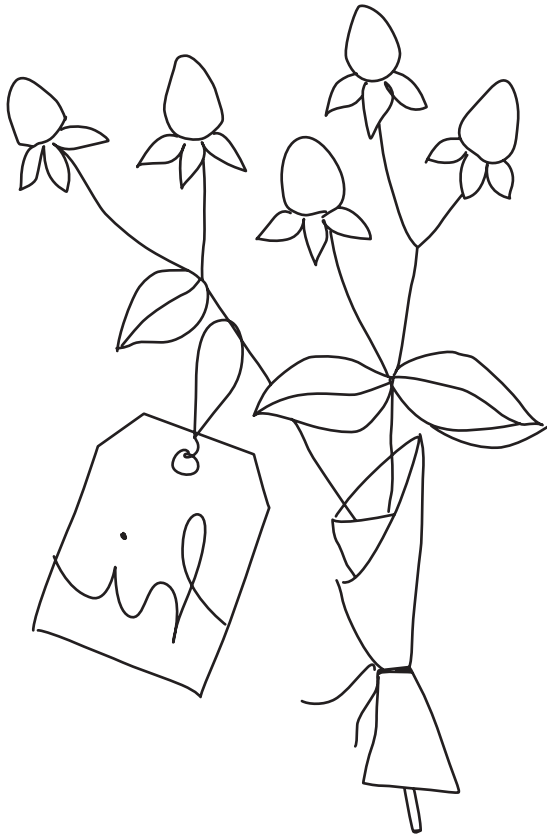

# Snowman & Doggy with Gift Boxes

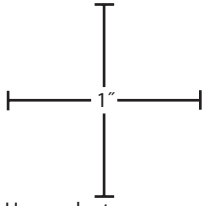

Use a ruler to measure these inch marks to verify that printout is correctly sized.

To make complete pattern, join the following pages, following the diagram for reference.

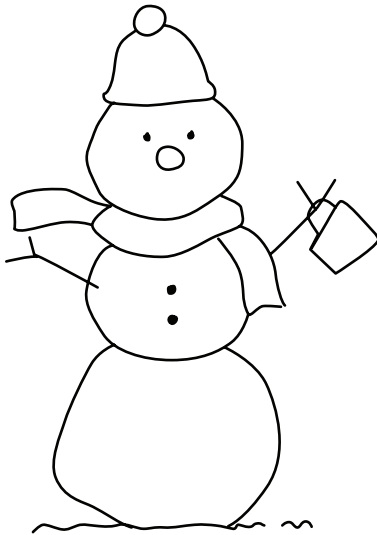

Humble Bundle

# Christmas Stockings

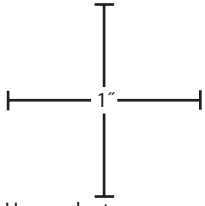

Use a ruler to measure these inch marks to verify that printout is correctly sized.

To make complete pattern, join the following pages, following the diagram for reference.

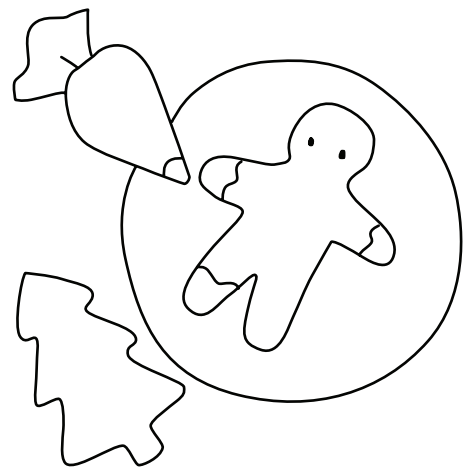
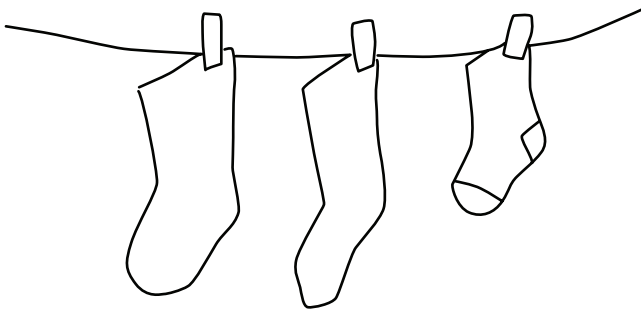
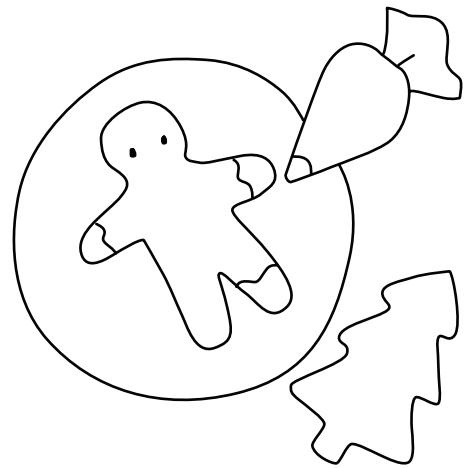
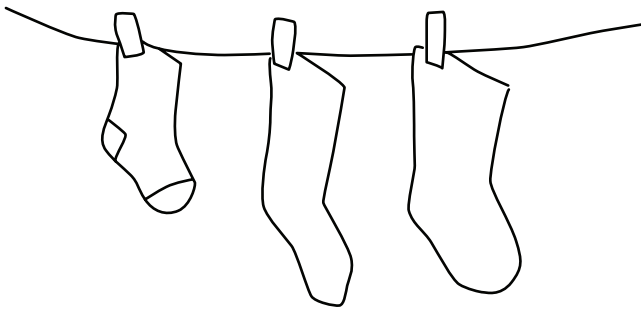

# Love Ya

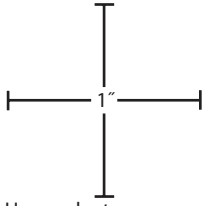

Use a ruler to measure these inch marks to verify that printout is correctly sized.

To make complete pattern, join the following pages, following the diagram for reference.



# Love Ya

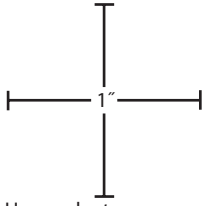

Use a ruler to measure these inch marks to verify that printout is correctly sized.

To make complete pattern, join the following pages, following the diagram for reference.



# Little Girl with Bear and Bunny

To make complete pattern, join the following pages, following the diagram for reference.

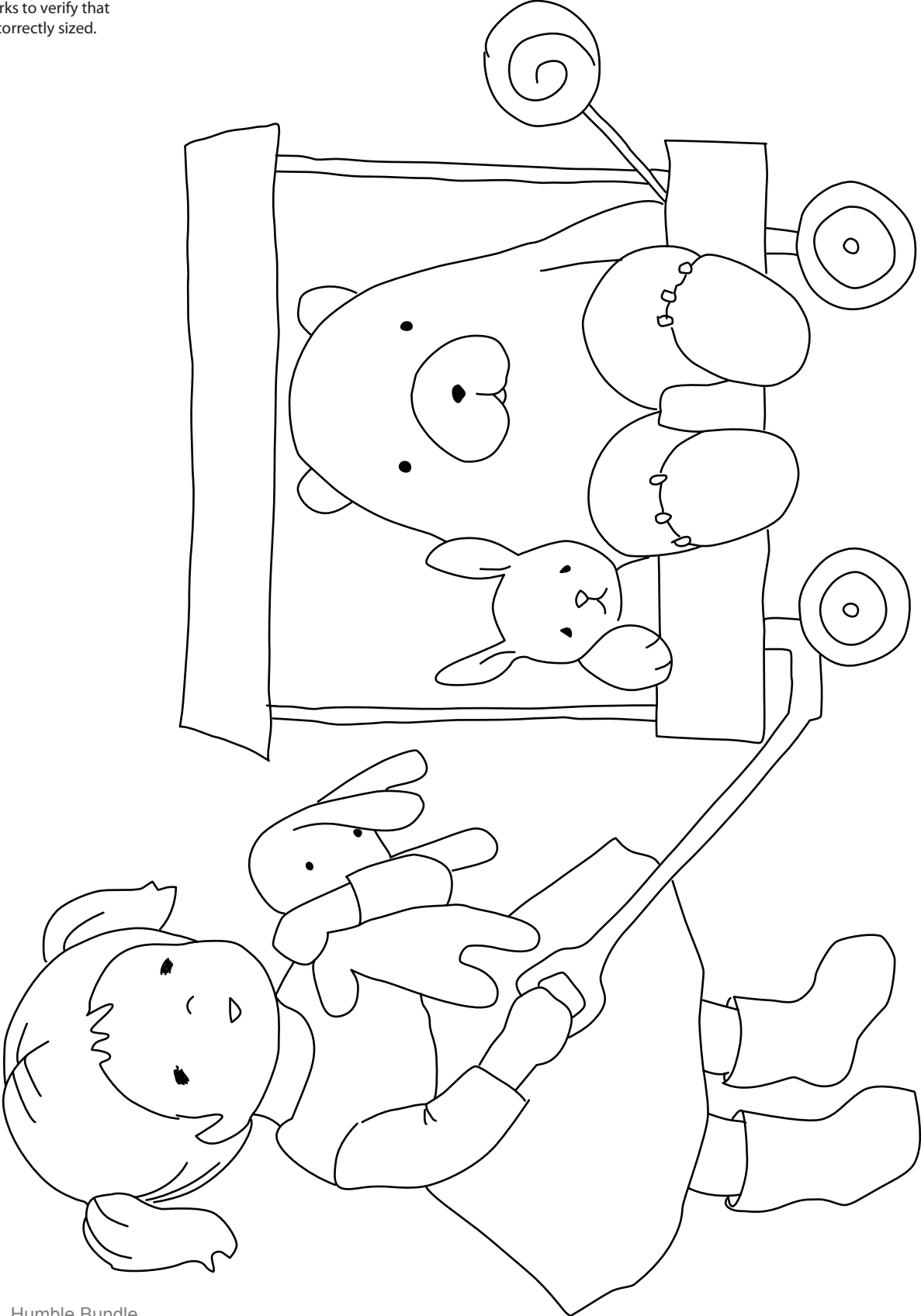
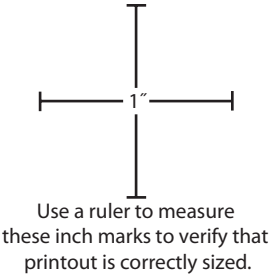

# Little Girl with Bear and Bunny

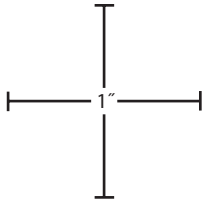

Use a ruler to measure these inch marks to verify that printout is correctly sized.

To make complete pattern, join the following pages, following the diagram for reference.

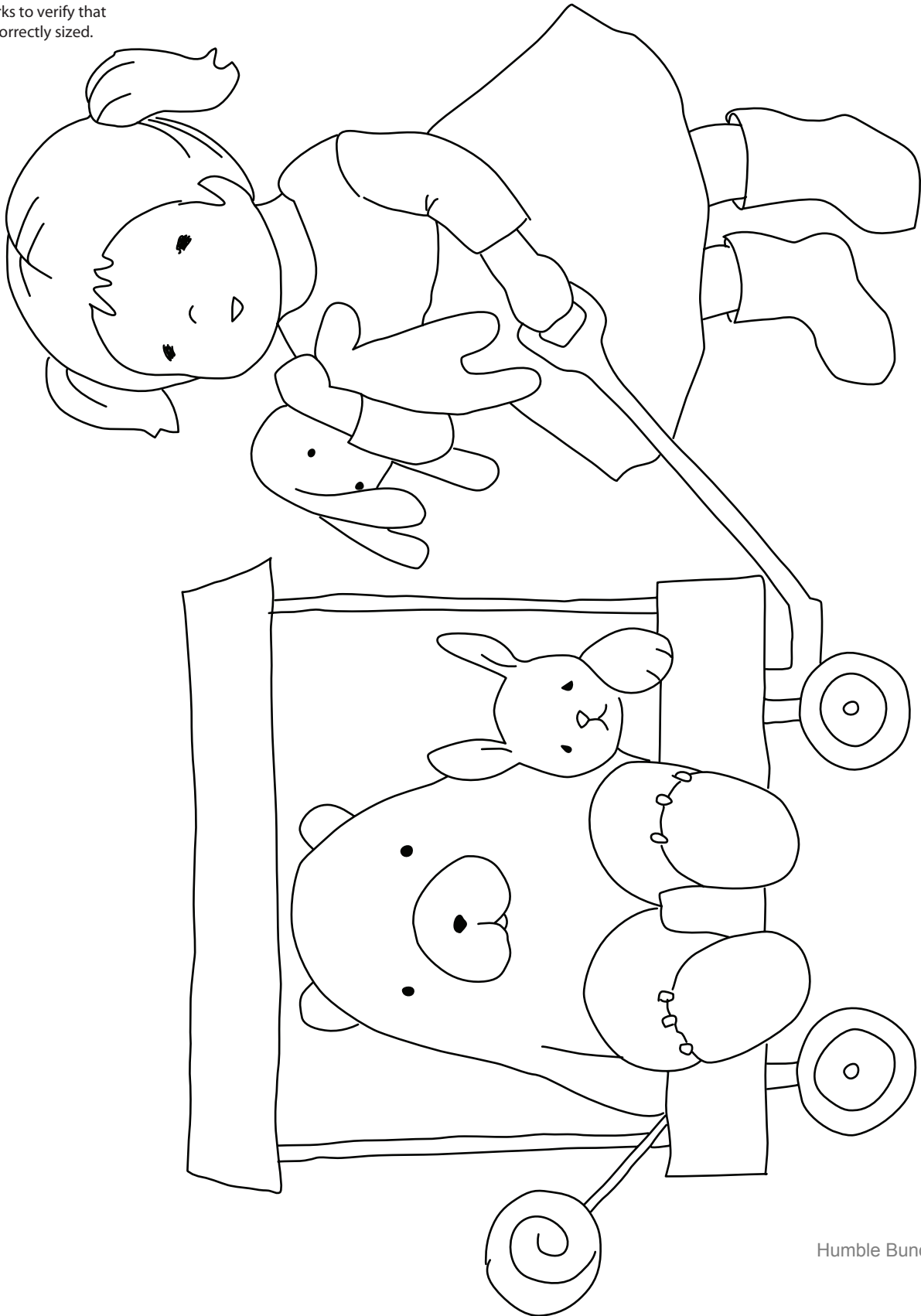

# Sewing Room

To make complete pattern, join the following pages, following the diagram for reference.

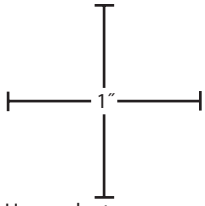

Use a ruler to measure these inch marks to verify that printout is correctly sized.

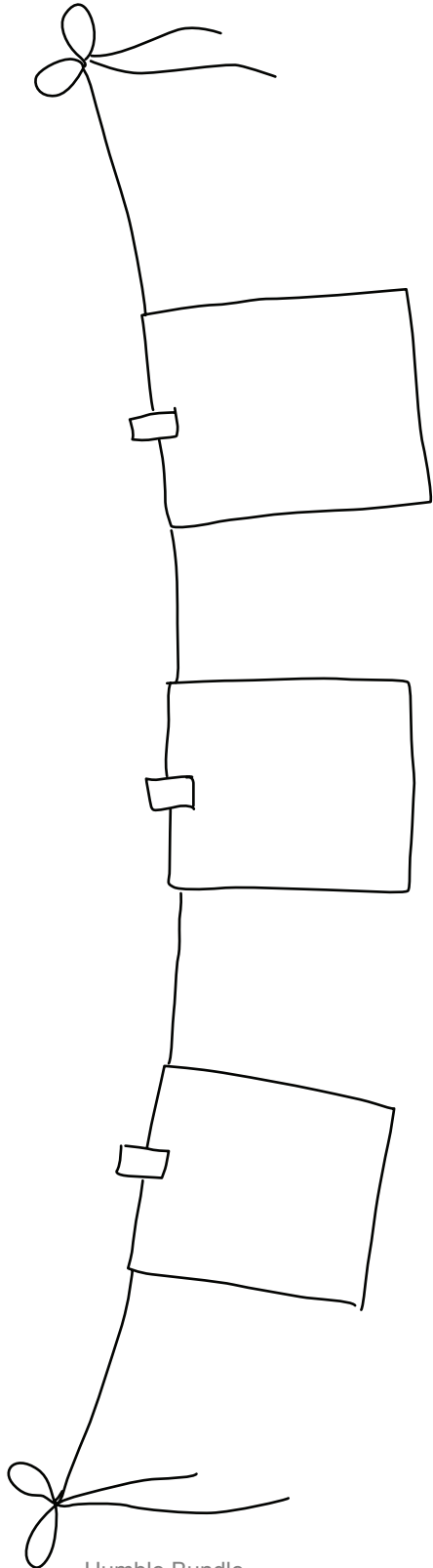

Humble Bundle

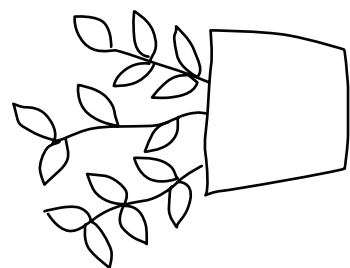
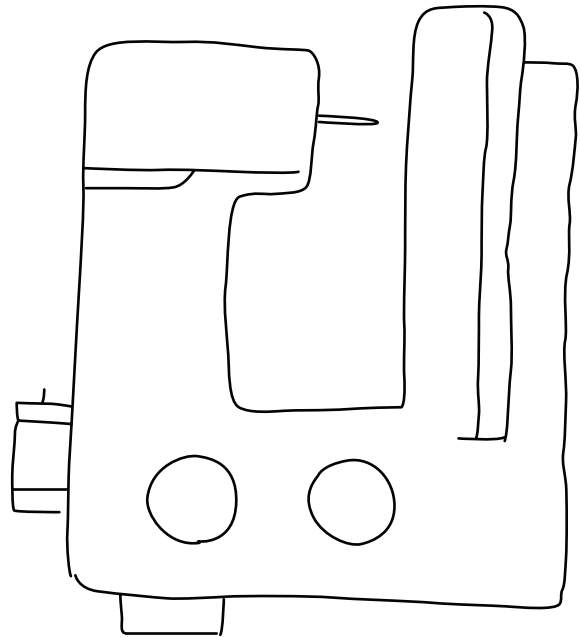
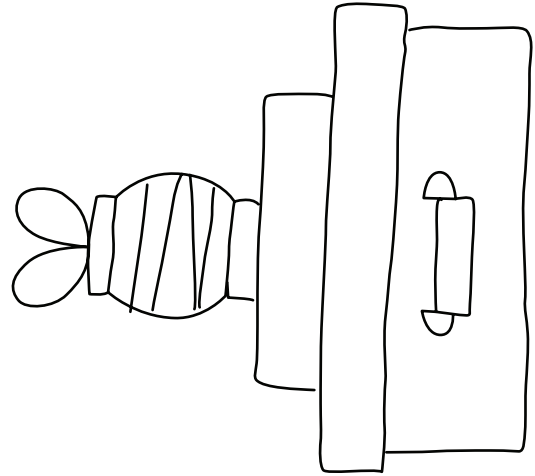



# Sewing Room

To make complete pattern, join the following pages, following the diagram for reference.

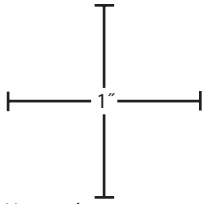

Use a ruler to measure these inch marks to verify that printout is correctly sized.

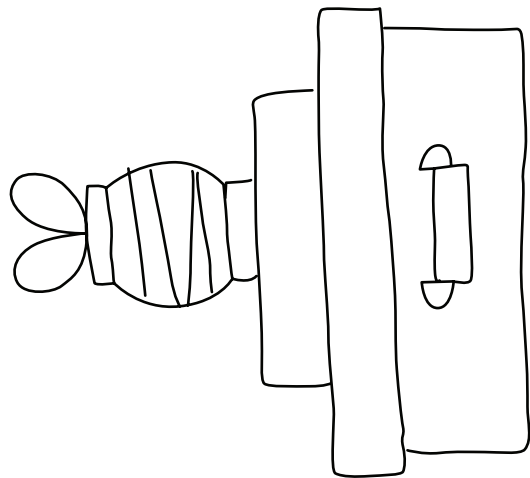
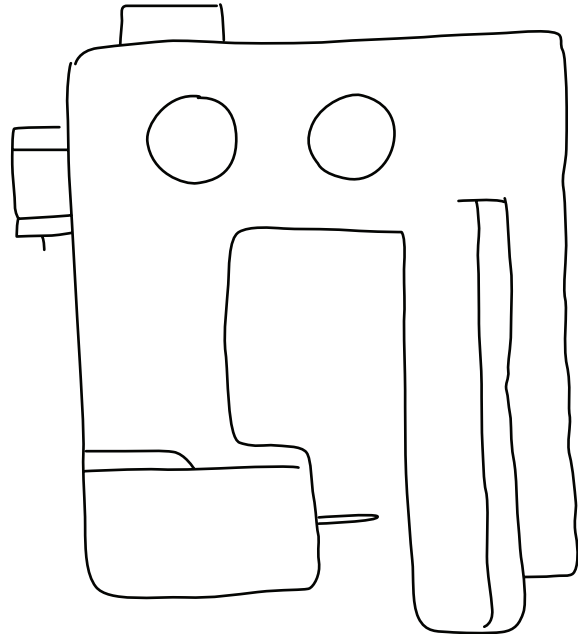
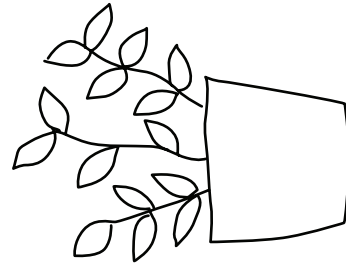
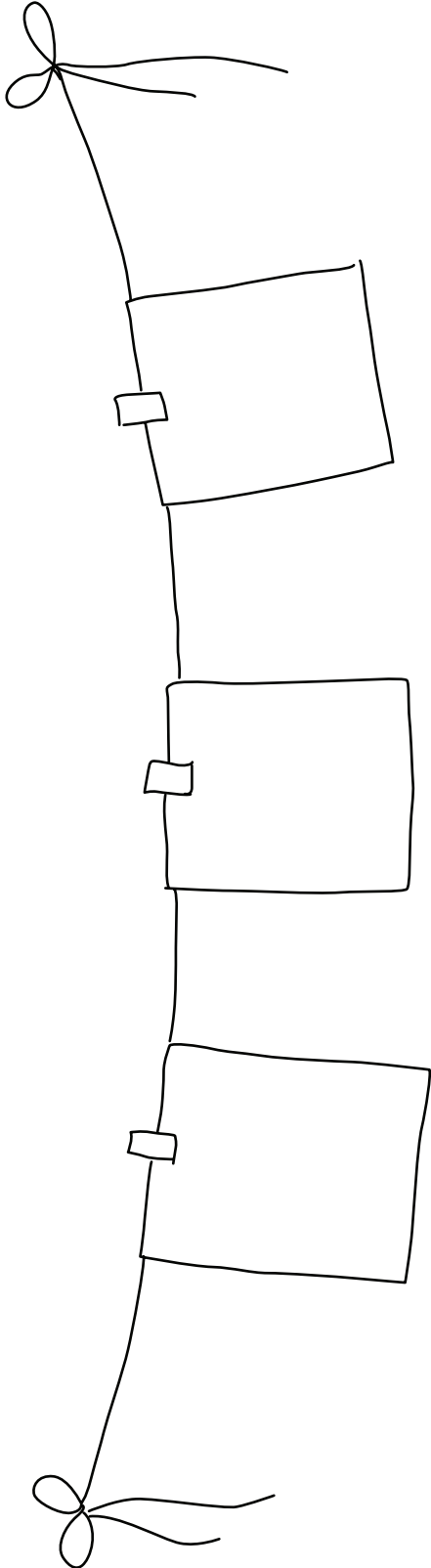

# Sweet Note

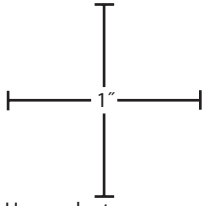

Use a ruler to measure these inch marks to verify that printout is correctly sized.

To make complete pattern, join the following pages, following the diagram for reference.

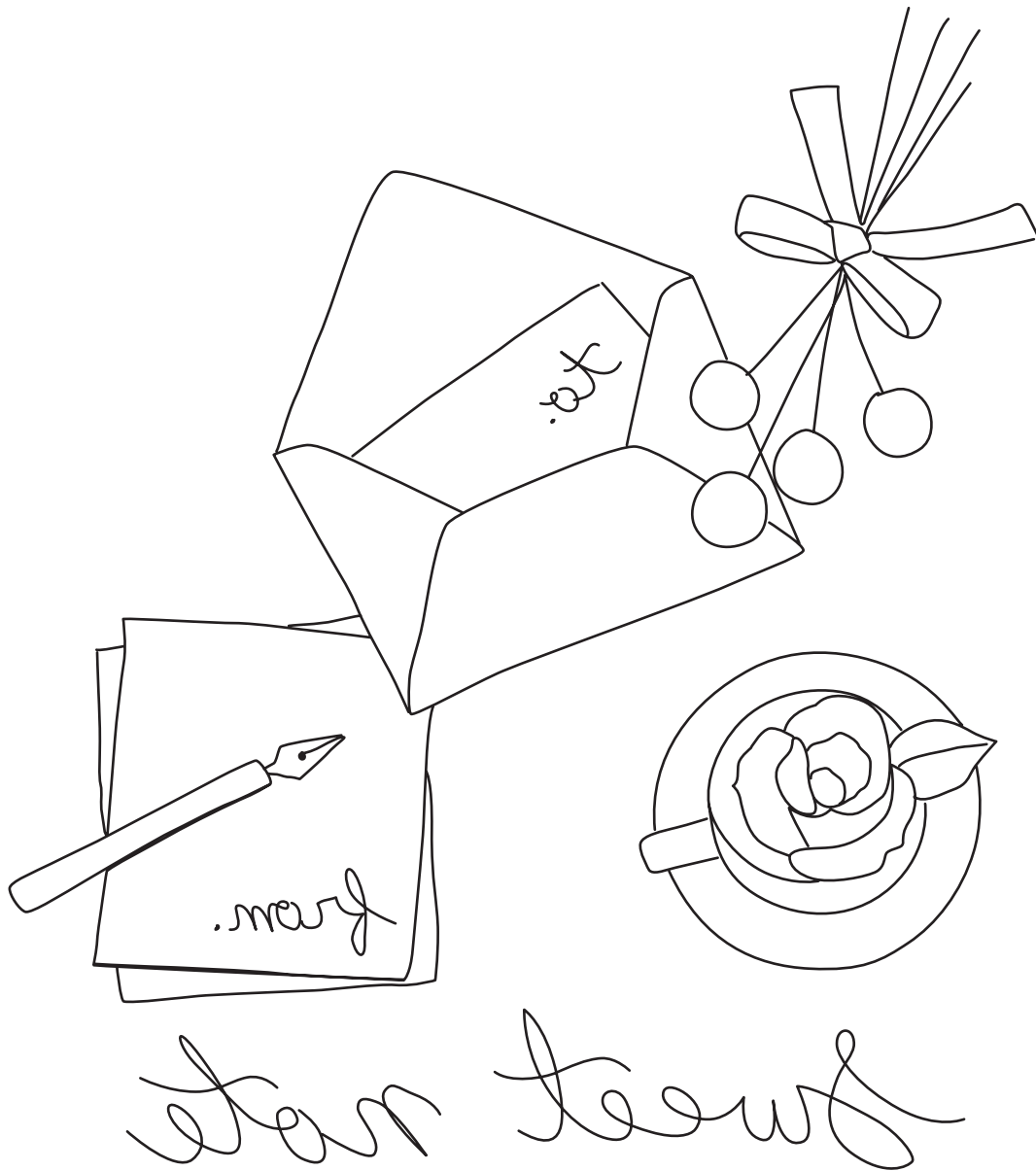

# Sweet Note

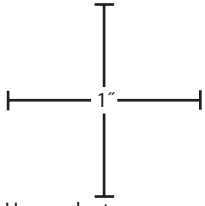

Use a ruler to measure these inch marks to verify that printout is correctly sized.

To make complete pattern, join the following pages, following the diagram for reference.

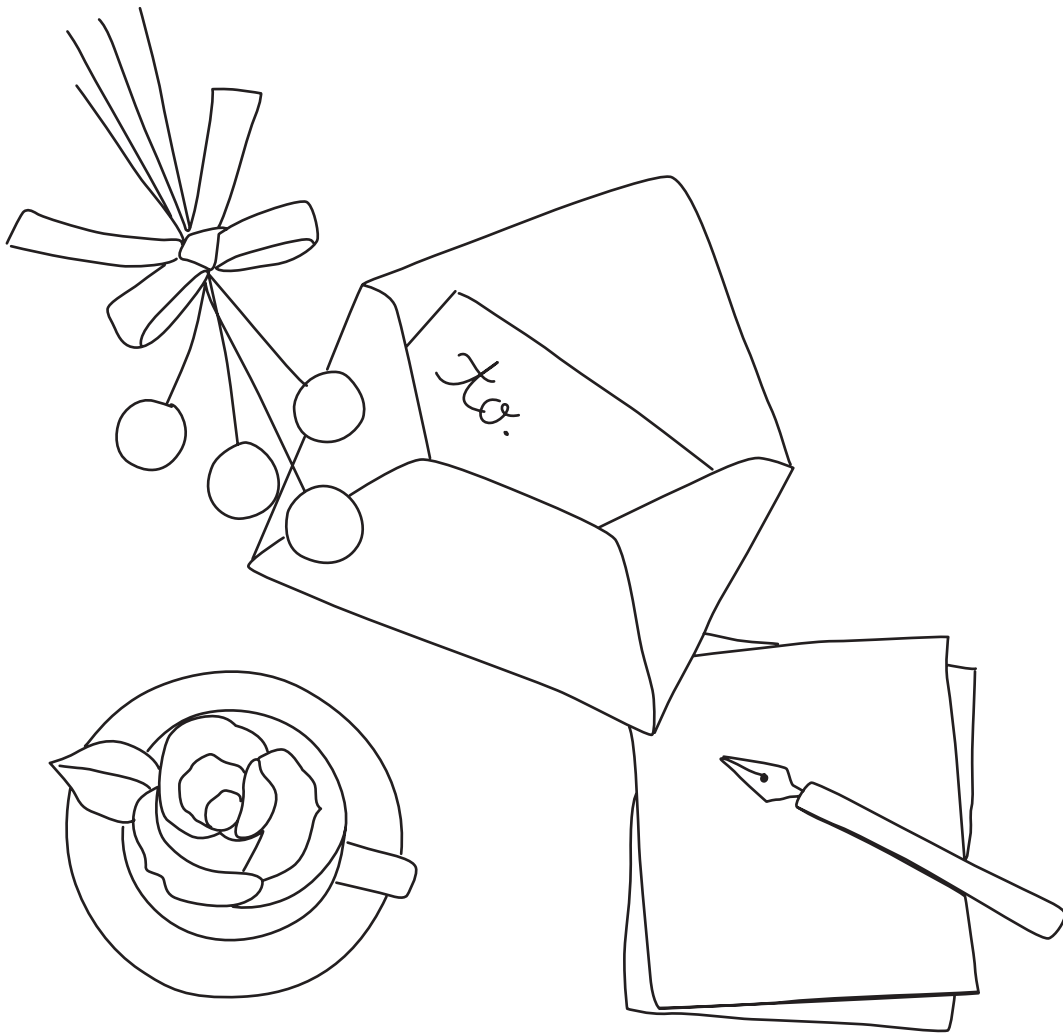

*Sweet note*

# Darling Sewing Case

To make complete pattern, join the following pages, following the diagram for reference.

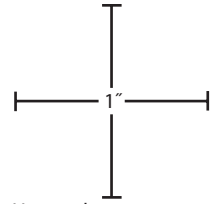

Use a ruler to measure these inch marks to verify that printout is correctly sized.

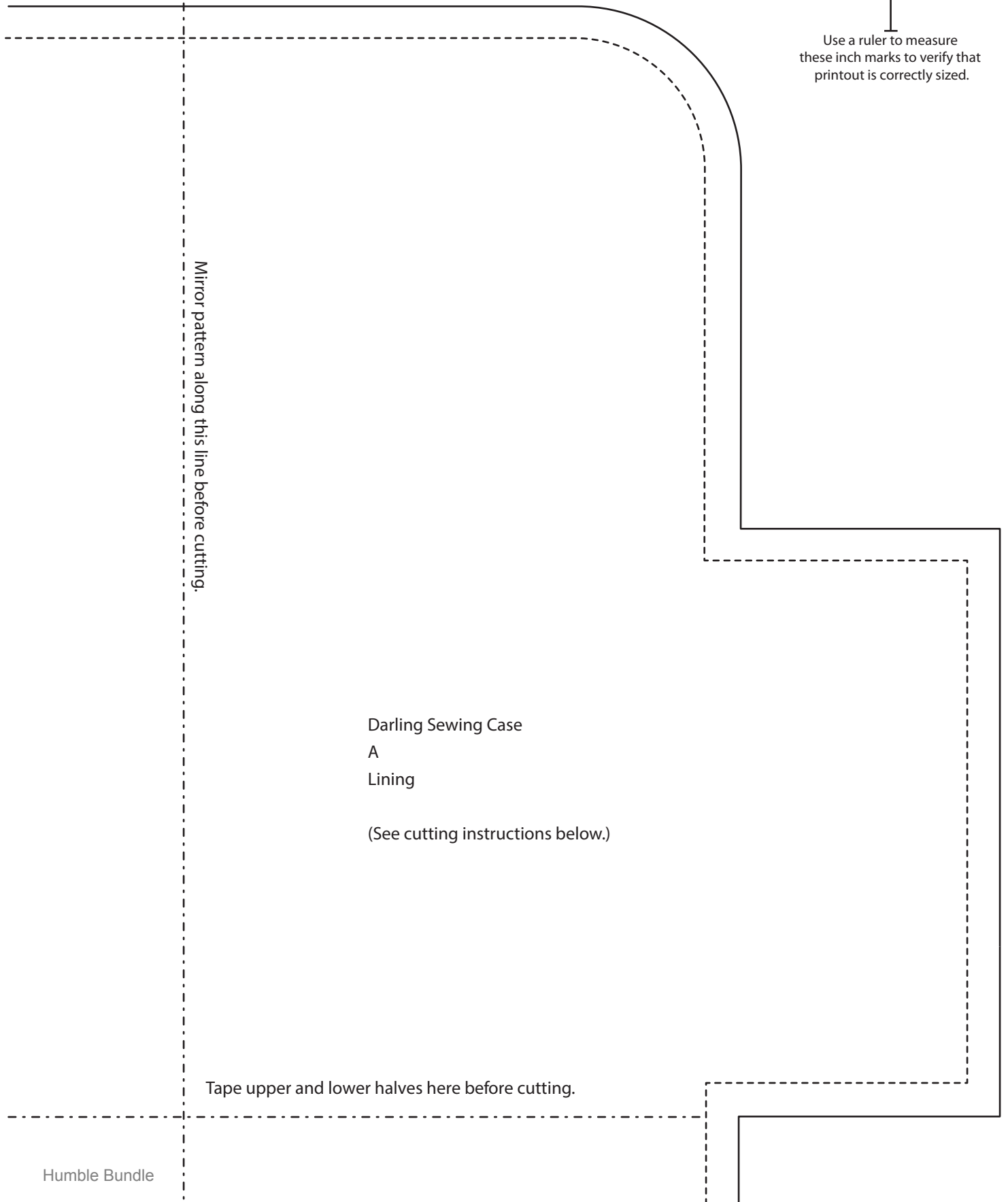

Mirror pattern along this line before cutting.

Darling Sewing Case  
A  
Lining  
  
(See cutting instructions below.)

Tape upper and lower halves here before cutting.

# Darling Sewing Case

To make complete pattern, join the following pages, following the diagram for reference.

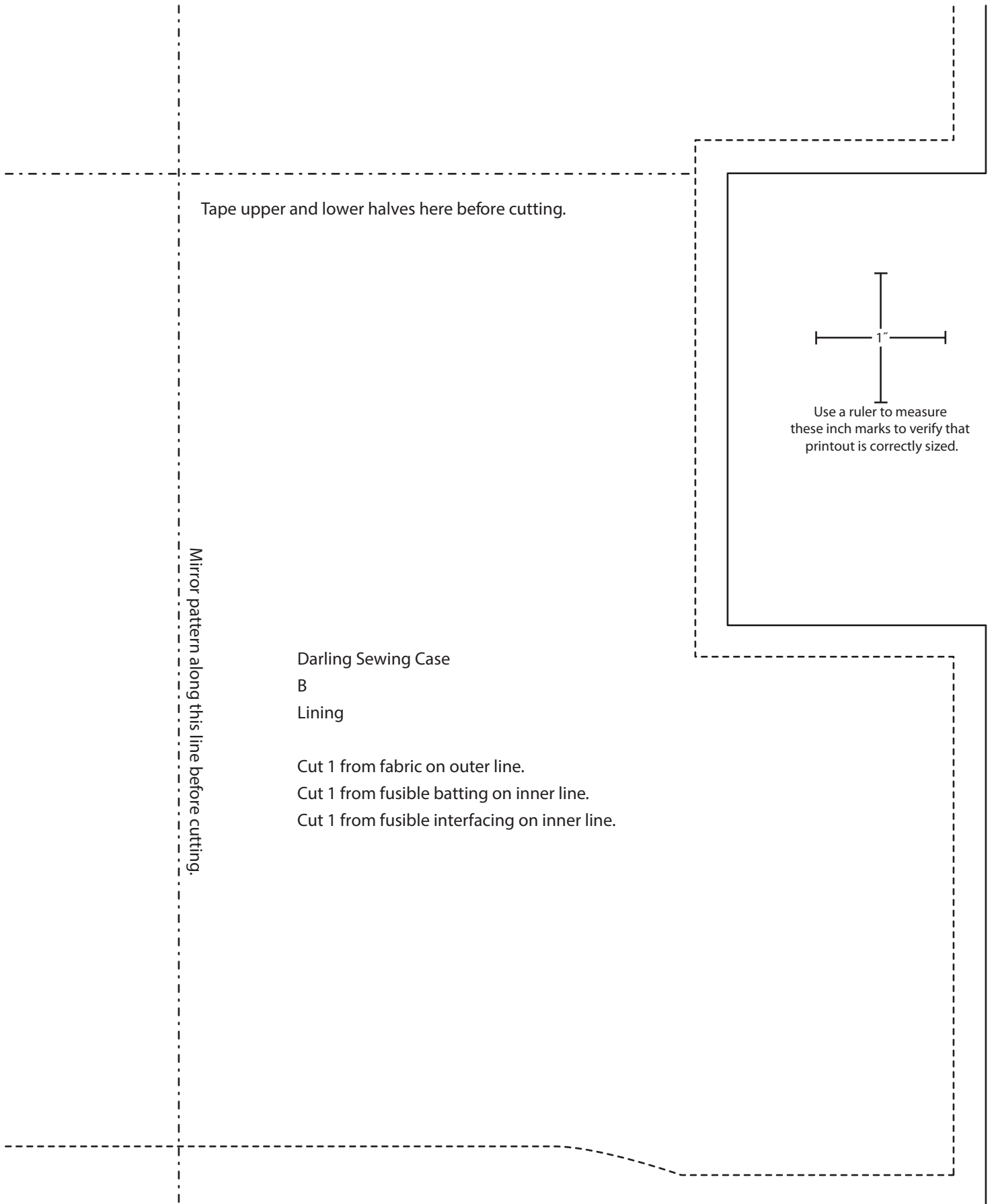

# Strawberry Zipper Pouch

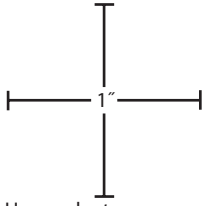

Use a ruler to measure these inch marks to verify that printout is correctly sized.

To make complete pattern, join the following pages, following the diagram for reference.

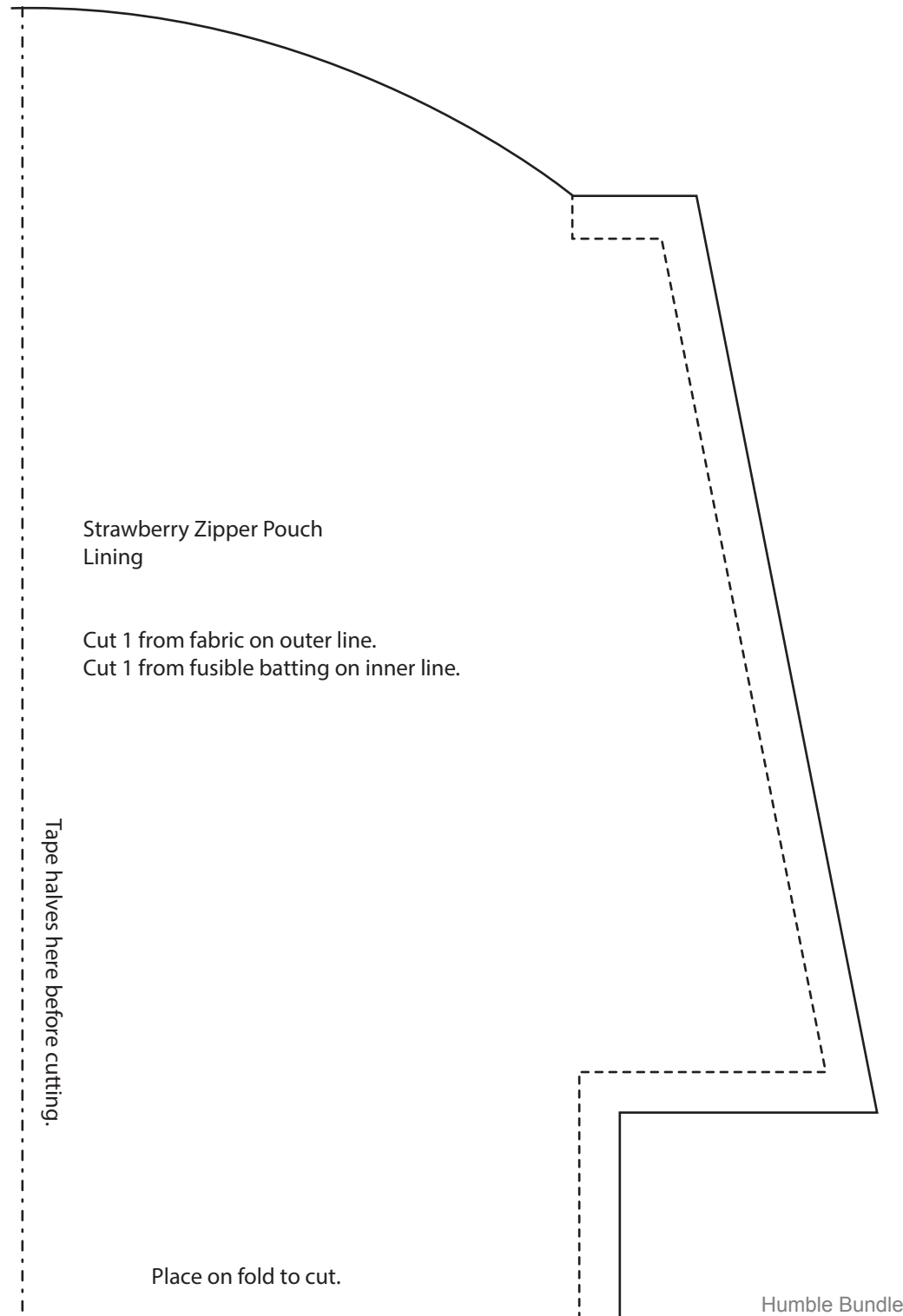

Strawberry Zipper Pouch  
Lining

Cut 1 from fabric on outer line.  
Cut 1 from fusible batting on inner line.

Tape halves here before cutting.

Place on fold to cut.

Humble Bundle

# Strawberry Zipper Pouch

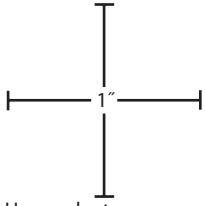

Use a ruler to measure these inch marks to verify that printout is correctly sized.

To make complete pattern, join the following pages, following the diagram for reference.

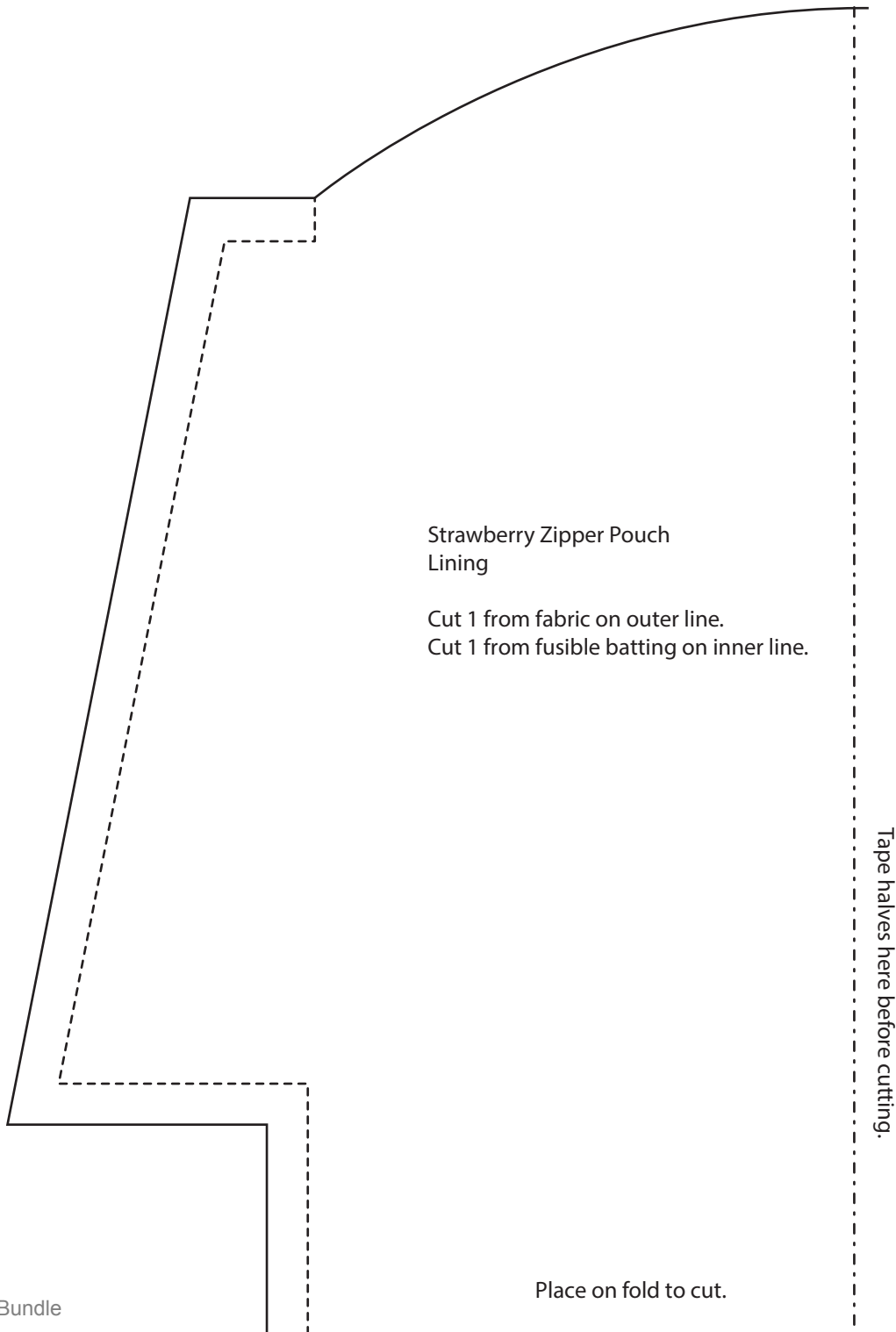

Strawberry Zipper Pouch  
Lining

Cut 1 from fabric on outer line.  
Cut 1 from fusible batting on inner line.

Tape halves here before cutting.

Place on fold to cut.

# Strawberry Zipper Pouch

To make complete pattern, join the following pages, following the diagram for reference.

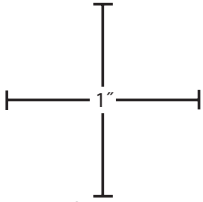
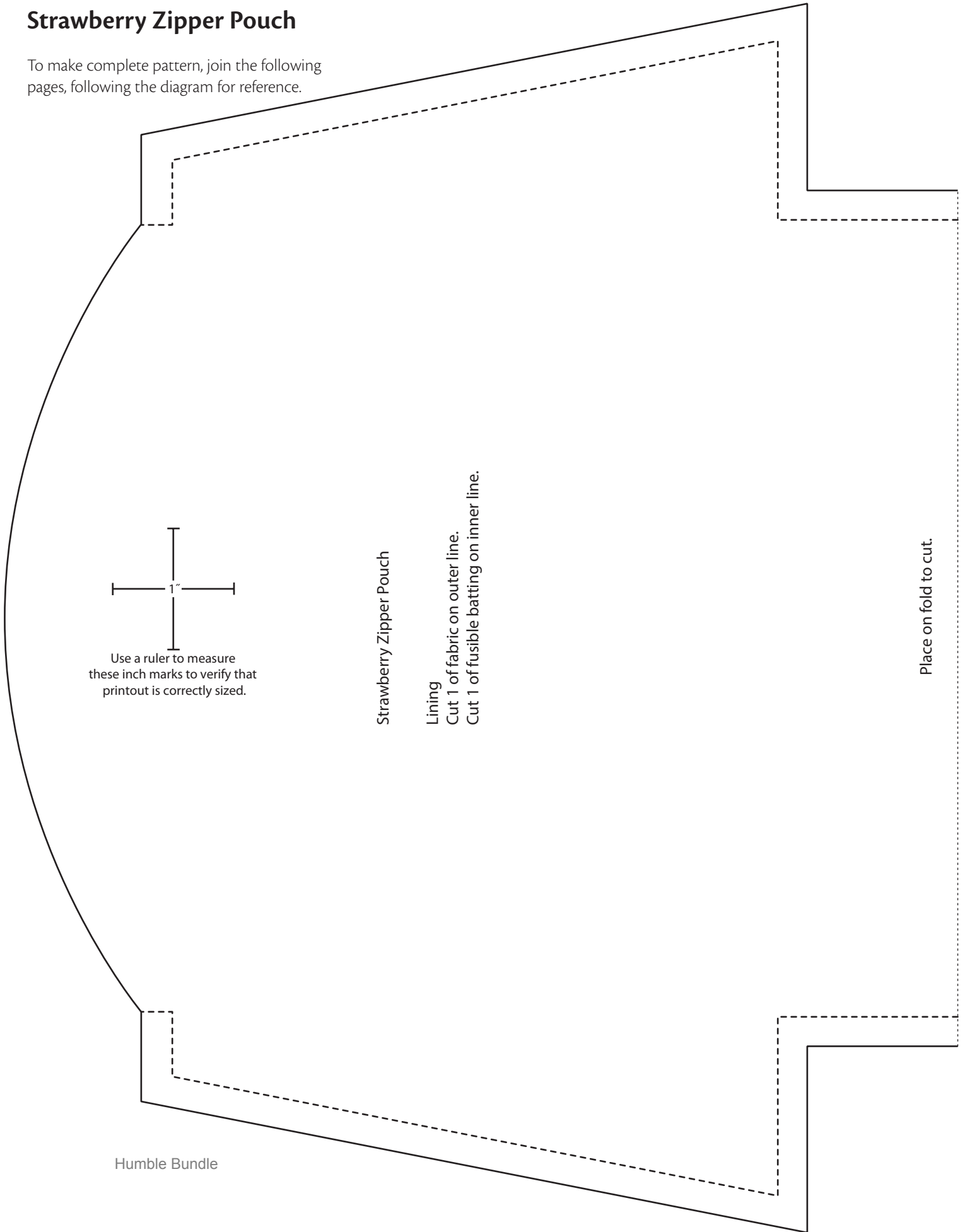

Use a ruler to measure these inch marks to verify that printout is correctly sized.

Strawberry Zipper Pouch

Lining

Cut 1 of fabric on outer line.

Cut 1 of fusible batting on inner line.

Place on fold to cut.



*Diary in Stitches* Download

Copyright © 2018 by C&T Publishing, Inc.

ISBN 978-1-61745-652-7

Published by C&T Publishing, Inc.,  
PO Box 1456, Lafayette, CA 94549.  
www.ctpub.com

All rights reserved. No part of this work covered by the copyright hereon may be used in any form or reproduced by any means—graphic, electronic, or mechanical, including photocopying, recording, taping, or information storage and retrieval systems—without written permission from the Publisher.

Acceptable uses of this ELECTRONIC PRODUCT:

1. Purchaser is entitled to print out as many copies of this ELECTRONIC PRODUCT as they wish for personal use. Photocopying, digitizing, and all other forms of copying to “share” or “distribute” the ELECTRONIC PRODUCT, whether for profit or not, is strictly prohibited.
2. Purchaser may not transfer the ELECTRONIC PRODUCT to any other person, via the Internet, email, on disk, in electronic or printed form or any other form without the written permission of C&T Publishing. Purchaser may not make the ELECTRONIC PRODUCT available over a network where it could be used by multiple computers at the same time.
3. Purchaser may not rent, lease, transfer, lend, or share the ELECTRONIC PRODUCT.

Limited Warranty: Limited Warranty on this ELECTRONIC PRODUCT. C&T Publishing, Inc. warrants the ELECTRONIC PRODUCT will be delivered by C&T Publishing, Inc. free from defects in materials and workmanship under normal use for a period of ninety (90) days from the date of original purchase. C&T Publishing, Inc. will not replace the ELECTRONIC PRODUCT due to Purchaser changing computers or accidentally deleting ELECTRONIC PRODUCT or for any other loss of the file that is considered out of the control of C&T Publishing, Inc. Your exclusive remedy under this Section shall be, at C&T Publishing, Inc.’s option, a refund of the purchase price of the ELECTRONIC PRODUCT.

Contact us at 800-284-1114 or [www.ctpub.com](http://www.ctpub.com) for more information about the C&T Teachers Program.

We take great care to ensure that the information included in our products is accurate and presented in good faith, but no warranty is provided nor are results guaranteed. Having no control over the choices of materials or procedures used, neither the author nor C&T Publishing, Inc., shall have any liability to any person or entity with respect to any loss or damage caused directly or indirectly by the information contained in this book. For your convenience, we post an up-to-date listing of corrections on our website ([www.ctpub.com](http://www.ctpub.com)). If a correction is not already noted, please contact our customer service department at [ctinfo@ctpub.com](mailto:ctinfo@ctpub.com) or at P.O. Box 1456, Lafayette, CA 94549.

Trademark (™) and registered trademark (®) names are used throughout this ELECTRONIC PRODUCT. Rather than use the symbols with every occurrence of a trademark or registered trademark name, we are using the names only in the editorial fashion and to the benefit of the owner, with no intention of infringement.

**Pattern Note:** This digital file contains patterns that may not print true to size and may require sizing adjustments (inchmarks are included on patterns for reference). Depending on your viewing application or device, printing desired page may result in multiple printed pages.

# C&T PUBLISHING

JOIN OUR E-FAMILY

**Pattern  
Spot.com**  
*We get you sewing*

access 1000s of patterns ▶

Best-Selling  
Quilting and  
Stitching apps

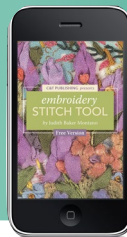

now for Android and iPhone! ▶

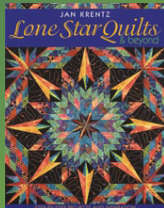

eBooks!

Instant, Easy,  
Portable & Affordable

go paperless! ▶



eNewsletter

Get Weekly  
Deals!

sign up now ▶

## Join the Conversation

community • free projects • prize giveaways

[stashbooksblog.com](http://stashbooksblog.com)

[ctpubblog](http://ctpubblog.com)



 **C&T PUBLISHING**  
Innovate. Educate. Create.

WEB [www.ctpub.com](http://www.ctpub.com)  
EMAIL [ctinfo@ctpub.com](mailto:ctinfo@ctpub.com)

TOLL-FREE IN U.S. 800.284.1114  
INT'L 925.677.0377  
FAX 925.677.0373



## Pretty projects to make you smile

Illustrate daily life in fabric and thread with sketches from the author's sketchbook

Stitch 65 creative motifs and 6 projects—a sewing machine cover, mini quilt, and more

Embroider and appliqué little gifts for the ones you love in Minki Kim's irresistible signature style

